

FINAL EXAM

Print your name and section clearly on all nine pages. (If you do not know your section number, write your TA's name.) Show all work in the space immediately below each problem. **Your final answer must be placed in the box provided.** Problems will be graded on reasoning and intermediate steps as well as on the final answer. Be sure to include units wherever necessary, and the direction of vectors. **Each problem is worth 25 points.** In doing the problems, try to be neat. Check your answers to see that they have the correct dimensions (units) and are the right order of magnitudes. You are allowed one 8.5" x 11" sheet and no other references. The exam lasts exactly two hours.

(Do not write below)

SCORE:

Problem 1: _____

Problem 2: _____

Problem 3: _____

Problem 4: _____

Problem 5: _____

Problem 6: _____

Problem 7: _____

Problem 8: _____

TOTAL: _____

Possibly useful information:

Acceleration due to gravity at the earth's surface: $g = 9.80 \text{ m/s}^2$

Gravitational Constant: $G = 6.67 \times 10^{-11} \text{ Nm}^2/\text{kg}^2$

1 calorie = 4.186 Joules

1 atm = $1.013 \times 10^5 \text{ Pa}$

Universal Gas Constant: $R = 8.314 \text{ J}/(\text{mol}\cdot\text{K})$

Stefan-Boltzmann Constant: $\sigma = 5.669 \times 10^{-8} \text{ W}/\text{m}^2\text{K}^4$

Avagadro's Number: $N_A = 6.022 \times 10^{23} \text{ molecules}/\text{mole}$

Boltzmann's Constant: $k_b = 1.38 \times 10^{-23} \text{ J}/\text{K}$

PROBLEM 1 Expanding Gas

8.00 g of O_2 gas (molecular weight 32.0 g/mol) is allowed to expand from an initial pressure of 1.10×10^5 Pa and volume of $2.00 \times 10^{-3} \text{ m}^3$ to a final pressure of 1.30×10^5 Pa and volume of $4.50 \times 10^{-3} \text{ m}^3$ along a path that forms a straight line on a p-V plot. Treat O_2 as an ideal gas with heat capacity $C_v = 4.97 \text{ cal/mol}\cdot\text{K}$.

a. What is the initial temperature of the gas in K? (5 pts.)

b. What is the final temperature of the gas in K? (5 pts.)

c. What was the change in internal energy of the gas? (5 pts.)

d. What is the work done by the gas? (5 pts.)

e. What is the heat flow into or out of the gas (specify which) during this process? (5 pts.)

PROBLEM 2 Rolling Right Along

A solid disc of mass 3.43 kg and radius 0.195 m is rolling along a horizontal surface without slipping. The linear speed of the center of mass of the disc along the horizontal surface is 2.13 m/s.

(Note: $I_{\text{disc}} = \frac{1}{2}MR^2$)

a. What is the angular speed of the disc? (5 pts.)

b. What is the angular momentum of the disc about its center of mass? (5 pts.)

c. What is the total kinetic energy of the disc? (5 pts.)

d. The disc encounters a ramp inclined by $\theta = 26.9^\circ$ to the horizontal and begins to roll up it without slipping. How high does the center of mass rise? (5 pts.)

e. A sphere (moment of inertia $I_s = \frac{2}{5}MR^2$) with the same mass and radius, and the same linear speed, rolls without slipping along the horizontal surface and encounters the ramp. Which rises higher, the disc or the sphere? (5 pts.)

PROBLEM 3 Hot Ball of Copper

A room contains a 150 g copper bowl with 220.0 g of water, all at 20.0°C. A hot 4.00 cm diameter 300.0 g copper sphere is dropped into the water, causing 5.00 g of water to become steam, with the rest of the water, the bowl and the sphere reaching 100.0°C. ($L_{\text{fusion}}(\text{water}) = 79.5 \text{ cal/g}$, $L_{\text{vapor}}(\text{water}) = 539 \text{ cal/g}$, $C_{\text{water}} = 1.00 \text{ cal/g}^\circ\text{C}$, $C_{\text{copper}} = 0.0923 \text{ cal/g}^\circ\text{C}$). Assume no heat transfer with surroundings.

a. What is the heat in kcal transferred to the water? (5 pts.)

b. What is the heat in kcal transferred to the bowl? (5 pts.)

c. What was the original temperature of the sphere in °C? (5 pts.)

d. By how many cm^3 did the volume of the sphere change during the temperature change? (5 pts.)
(Coefficient of linear expansion of copper is $1.80 \times 10^{-5}/^\circ\text{C}$)

e. What is the thermal radiation power in Watts produced by the sphere (emissivity 0.700) just before it is dropped in the water? (5 pts.)

PROBLEM 4 The Fate of the Balloon

A child holds a balloon, of volume 0.0550 m^3 , filled with helium. The temperature of the helium is 288 K , and the pressure of the helium is $1.13 \times 10^5 \text{ Pa}$ ($\gamma=5/3$ for helium; the mass of a helium atom is $6.6488 \times 10^{-27} \text{ kg}$). The external air pressure is $1.01 \times 10^5 \text{ Pa}$, the external air temperature is 288 K , and the external air density is 1.226 kg/m^3 .

a. How many helium atoms are in the balloon? (5 pts.)

b. What is the total internal energy of the helium? (5 pts.)

c. What is the root-mean-square speed of the helium atoms? (5 pts.)

d. What is the buoyant force on the balloon? (5 pts.)

e. The child accidentally lets go of the balloon. After 5 minutes the balloon is at a height of 2000 m , and the pressure inside the balloon has dropped to $9.00 \times 10^4 \text{ Pa}$. Assuming the balloon expands adiabatically, what is the new volume of the balloon? (5 pts.)

PROBLEM 5 Tennis Ball Cannon

A tennis ball cannon is buried so that the end of its barrel is at the level of the ground, which is flat. A tennis ball (mass $m=58.0\text{ g}$) is pushed down against a spring (spring constant $k=2450\text{ N/m}$), compressing it by 21.1 cm from its natural length.

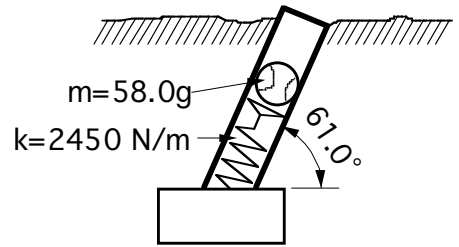

a. What is the energy stored in the spring? (5 pts.)

b. What is the speed of the tennis ball immediately after it loses contact with the spring? (5 pts.)

c. The barrel of the cannon is inclined by 61.0° to the horizontal. What is the horizontal range of the tennis ball? (5 pts.)

d. What is the maximum height of the tennis ball? (5 pts.)

e. Express the velocity vector of the tennis ball at the instant before it strikes the ground in terms of the unit vectors \mathbf{i} and \mathbf{j} . (5 pts.)

PROBLEM 6 Just Mooning Around

The mass of the Earth is $M=5.98 \times 10^{24}$ kg and the radius of the Earth is $R=6.37 \times 10^6$ m.

The mass of the moon is $m=7.35 \times 10^{22}$ kg and the radius of the moon is $r=1.74 \times 10^6$ m.

Assume the moon's orbit is a circle with radius $a=3.84 \times 10^8$ m.

a. What is the magnitude of the gravitational force exerted by the Earth on the moon? (5 pts.)

b. Write an expression for the orbital period of the moon, and numerically solve it in terms of seconds. (Please show all work) (5 pts.)

c. What is the distance between the center of the Earth and the center of mass of the Earth-Moon system? (5 pts.)

d. How much work would have to be done against the Earth's gravitational field to lift a single-stage rocket (mass=28800 kg) from the Earth's surface to the radius of the moon's orbit? (5 pts.)

e. What is the speed at launch (ignoring air resistance) that this rocket would need if it were to arrive at the radius of the moon's orbit having zero speed? (5 pts.)

PROBLEM 7 Pulleys, Weights, and Spring

A 192 kg mass hangs from a system of pulleys as shown in the diagram. The other end of the rope is fastened to a 31 kg mass that rests on a frictionless surface and is connected to a spring ($k=95 \text{ N/m}$). Assume an ideal rope and massless, frictionless pulleys.

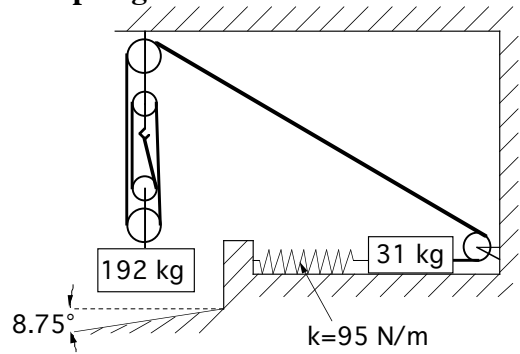

a. What is the tension in the rope? (5 pts.)

b. What is the length by which the spring is stretched beyond its natural length? (5 pts.)

c. The rope is cut. What is the frequency of oscillation of the small mass? (5 pts.)

d. What is the maximum linear momentum of the small mass? (5 pts.)

e. The large mass lands straight down on a plane inclined by 8.75° to the horizontal, with coefficient of friction $\mu_k=0.050$. After the block is fully in contact with the plane, and sliding down, find its acceleration in the direction parallel to the surface of the plane. (5 pts.)

Problem 8 A Hot Engine

Researchers at Physics 201 Labs invent a heat engine, which runs on the Carnot cycle between reservoirs at 273 K and 755 K, with 78% of maximum possible theoretical efficiency.

a. What is the efficiency of this heat engine? (5 pts.)

b. If the heat engine absorbs 6.87×10^4 J per second from the hot reservoir, how much power can it produce? (5 pts.)

c. The heat Q_{out} rejected from the engine is used to melt ice (latent heat of fusion: $L_f = 3.33 \times 10^5$ J/kg). How much ice can be melted in a minute?

d. What is the theoretical maximum possible coefficient of performance of a heat pump operating between these two temperatures (i.e. 273 K and 755 K)? (5 pts.)

e. What is the net change in the entropy of the universe after one cycle of an ideal Carnot cycle heat engine? (Make sure to use correct units) (5 pts.)