

## Chapter Outline

- 26.1 Introduction
- 26.2 The Principle of Relativity
- 26.3 The Speed of Light
- 26.4 The Michelson–Morley Experiment
- 26.5 Einstein's Principle of Relativity
- 26.6 Consequences of Special Relativity
- 26.7 Relativistic Momentum
- 26.8 Relativistic Addition of Velocities
- 26.9 Relativistic Energy
- 26.10 General Relativity (Optional)



### ▲ PHYSICS PUZZLER

A police officer can clock the speed of your automobile with a radar device. This device works using the Doppler effect for electromagnetic waves discussed in Chapter 21. Is it possible to accelerate an object such as a rocket to a speed greater than the speed of light? (Trent Steffler/David R. Frazier Photolibrary)

## 26.1 INTRODUCTION

Most of our everyday experiences and observations deal with objects that move at speeds much lower than the speed of light. Newtonian mechanics and the early ideas on space and time were formulated to describe the motion of such objects. As we saw in the chapters on mechanics, this formalism is very successful in describing a wide range of phenomena. Although Newtonian mechanics works very well at low speeds, it fails when applied to particles whose speeds approach that of light. The predictions of Newtonian theory at high speeds can be tested by accelerating an electron through a large electric potential difference. For example, it is possible to accelerate an electron to a speed of  $0.99c$  by using a potential difference of several million volts. According to Newtonian mechanics, if the potential difference (as well as the corresponding energy) is increased by a factor of 4, then the speed of the electron should be doubled to  $1.98c$ . However, experiments show that the speed of the electron always remains *lower* than the speed of light, regardless of the size of the accelerating voltage. Because Newtonian mechanics places no upper limit on the speed that a particle can attain, it is contrary to modern experimental results and is clearly a limited theory.

In 1905, at the age of 26, Einstein published his special theory of relativity. Regarding the theory, Einstein wrote,

The relativity theory arose from necessity, from serious and deep contradictions in the old theory from which there seemed no escape. The strength of the new theory lies in the consistency and simplicity with which it solves all these difficulties, using only a few very convincing assumptions.<sup>1</sup>

Although Einstein made many other important contributions to science, his theory of relativity alone represents one of the greatest intellectual achievements of the 20th century. With this theory, experimental observations over the range from  $v = 0$  to speeds approaching the speed of light can be predicted. Newtonian mechanics, which was accepted for more than 200 years, is in fact a specialized case of Einstein's theory. This chapter introduces the special theory of relativity, with emphasis on some of the consequences of the theory. A discussion of general relativity and some of its consequences is presented in Section 26.10.

As we shall see, the special theory of relativity is based on two postulates:

1. **The laws of physics are the same in all inertial reference systems.**
2. **The speed of light in a vacuum is always measured to be  $3 \times 10^8$  m/s, and the measured value is independent of the motion of the observer or of the motion of the source of light.**

Special relativity covers such phenomena as the slowing down of moving clocks and the contraction of moving rods as measured by a stationary observer. In addition to these topics, we also discuss the relativistic forms of momentum and energy, terminating the chapter with the famous mass-energy equivalence formula,  $E = mc^2$ .

<sup>1</sup> A. Einstein and L. Infeld, *The Evolution of Physics*, New York, Simon and Schuster, 1961.

### Thinking Physics 1

Imagine a very powerful lighthouse with a rotating beacon. Imagine also drawing a horizontal circle around the lighthouse, with the lighthouse at the center. Along the circumference of the circle, the light beam lights up a portion of the circle and the lit portion of the circle moves around the circle at a certain tangential speed. If we now imagine a circle twice as big in radius, the tangential speed of the lit portion is faster, because it must travel a larger circumference in the time of one rotation of the light source. Imagine that we continue to make the circle larger and larger, eventually moving it out into space. The tangential speed of the lit portion will keep increasing. Is it possible that the tangential speed could become larger than the speed of light? Would this violate a principle of special relativity?

**Explanation** For a large enough circle, it is possible that the tangential speed of the lit portion of the circle could be larger than the speed of light. This does not violate a principle of special relativity, however, because no matter or information is traveling faster than the speed of light.

## 26.2 THE PRINCIPLE OF RELATIVITY

In order to describe a physical event, it is necessary to choose a *frame of reference*. For example, when you perform an experiment in a laboratory, you select a coordinate system, or frame of reference, that is at rest with respect to the laboratory. However, suppose an observer in a passing car moving at a constant velocity with respect to the lab were to observe your experiment. Would the observations made by the moving observer differ dramatically from yours? That is, if you found Newton's first law to be valid in your frame of reference, would the moving observer agree with you? According to the principle of Newtonian relativity, **the laws of mechanics are the same in all inertial frames of reference**. Inertial frames of reference are those reference frames in which Newton's first law, the law of inertia, is valid. For the situation just described, the laboratory coordinate system and the coordinate system of the moving car are both inertial frames of reference. As a consequence, if the laws of mechanics are found to be true in the lab, the person in the car must also observe the same laws.

Let us describe a common observation to illustrate the equivalence of the laws of mechanics in different inertial frames. Consider an airplane in flight, moving with a constant velocity, as in Figure 26.1a. If a passenger in the airplane throws a ball straight up in the air, the passenger observes that the ball moves in a vertical path. The motion of the ball is precisely the same as it would be if the ball were thrown while at rest on Earth. The law of gravity and the equations of motion under constant acceleration are obeyed whether the airplane is at rest or in uniform motion. Now consider the same experiment when viewed by another observer at rest on the Earth. This stationary observer views the path of the ball to be a parabola, as in Figure 26.1b. Furthermore, according to this observer, the ball has a velocity to the right equal to the velocity of the plane. Although the two observers disagree in certain aspects of the experiment, both agree that the motion of the ball obeys

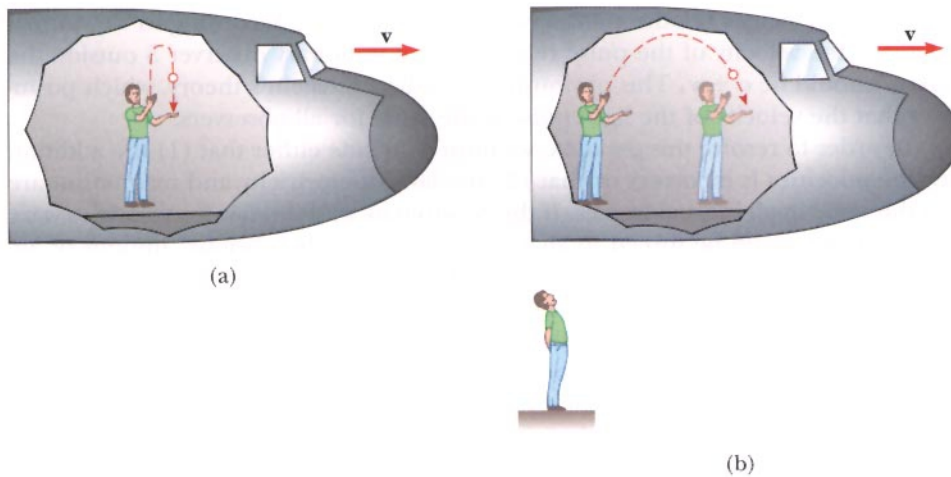
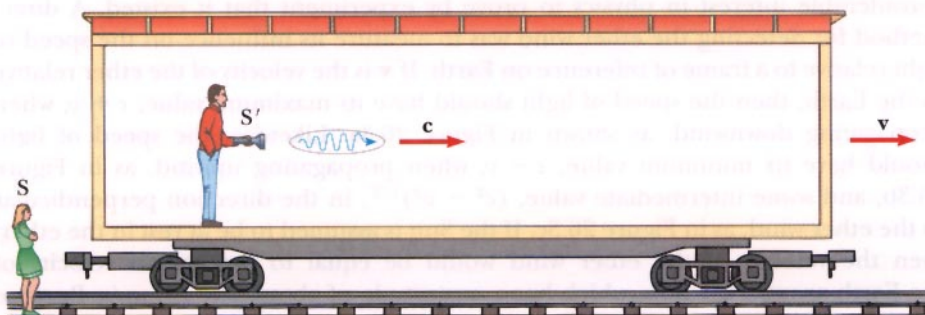

**Figure 26.1** (a) The observer on the airplane sees the ball move in a vertical path when thrown upward. (b) The Earth observer views the path of the ball to be a parabola.

the law of gravity and Newton's laws of motion. Thus, we draw the following important conclusion: **There is no preferred frame of reference for describing the laws of mechanics.**

## 26.3 THE SPEED OF LIGHT

It is quite natural to ask whether the concept of Newtonian relativity in mechanics also applies to experiments in electricity, magnetism, optics, and other areas. For example, if we assume that the laws of electricity and magnetism are the same in all inertial frames, a paradox concerning the speed of light immediately arises. This can be understood by recalling that according to electromagnetic theory, the speed of light always has the fixed value of  $2.997\,924\,58 \times 10^8$  m/s in free space. But this is in direct contradiction to common sense. For example, suppose a light pulse is sent out by an observer in a boxcar moving with a velocity  $v$  (Fig. 26.2). The light



**Figure 26.2** A pulse of light is sent out by a person in a moving boxcar. According to Newtonian relativity, the speed of the pulse should be  $c + v$  relative to a stationary observer.

pulse has a velocity  $c$  relative to observer  $S'$  in the boxcar. According to Newtonian relativity, the velocity of the pulse relative to the stationary observer  $S$  outside the boxcar should be  $c + v$ . This obviously contradicts Einstein's theory, which postulates that the velocity of the light pulse is the same for all observers.

In order to resolve this paradox, we must conclude either that (1) the addition law for velocities is incorrect or that (2) the laws of electricity and magnetism are not the same in all inertial frames. If the Newtonian addition law for velocities is incorrect, we would be forced to abandon the seemingly "obvious" notions of absolute time and absolute length that form the basis for this law.

If instead we assume that the second conclusion is true, then a preferred reference frame must exist in which the speed of light has the value  $c$ , whereas in other reference frames the speed of light must have a value that is greater or less than  $c$ . It is useful to draw an analogy with sound waves, which propagate through a medium such as air. The speed of sound in air is about 330 m/s when measured in a reference frame in which the air is stationary. However, the speed of sound is greater or less than this value when measured from a reference frame that is moving with respect to the air.

In the case of light signals (electromagnetic waves), recall that electromagnetic theory predicted that such waves must propagate through free space at a speed equal to the speed of light. However, the theory does not require the presence of a medium for wave propagation. This is in contrast to other types of waves that we have studied, such as water and sound waves, that do require a medium to support the disturbances. In the 19th century, physicists thought that electromagnetic waves also required a medium in order to propagate. They proposed that such a medium existed, and they gave it the name **luminiferous ether**. The ether was assumed to be present everywhere, even in empty space, and light waves were viewed as ether oscillations. Furthermore, the ether would have to be a massless but rigid medium with no effect on the motion of planets or other objects. These are strange concepts indeed. In addition, it was found that the troublesome laws of electricity and magnetism would take on their simplest forms in a frame of reference at rest with respect to the ether. This frame was called the *absolute frame*. The laws of electricity and magnetism would be valid in this absolute frame, but they would have to be modified in any reference frame moving with respect to the absolute frame.

As a result of the importance attached to this absolute frame, it became a matter of considerable interest in physics to prove by experiment that it existed. A direct method for detecting the ether wind was to measure its influence on the speed of light relative to a frame of reference on Earth. If  $v$  is the velocity of the ether relative to the Earth, then the speed of light should have its maximum value,  $c + v$ , when propagating downwind, as shown in Figure 26.3a. Likewise, the speed of light should have its minimum value,  $c - v$ , when propagating upwind, as in Figure 26.3b, and some intermediate value,  $(c^2 - v^2)^{1/2}$ , in the direction perpendicular to the ether wind, as in Figure 26.3c. If the Sun is assumed to be at rest in the ether, then the velocity of the ether wind would be equal to the orbital velocity of the Earth around the Sun, which has a magnitude of about  $3 \times 10^4$  m/s. Because  $c = 3 \times 10^8$  m/s, a change in speed of about 1 part in  $10^4$  m/s for measurements in the upwind or downwind directions should be detectable. However, as we see in the next section, all attempts to detect such changes and establish the existence of the ether failed.

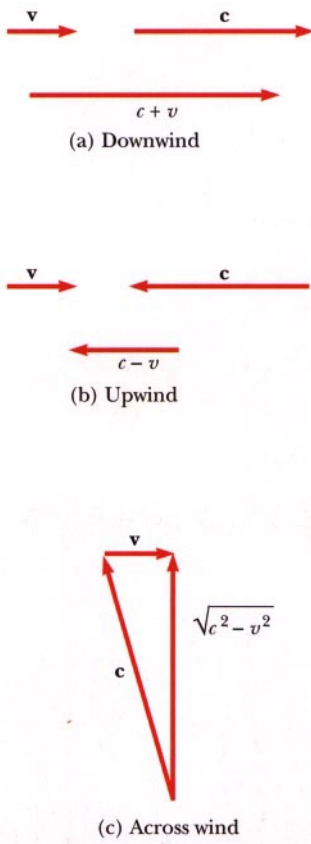
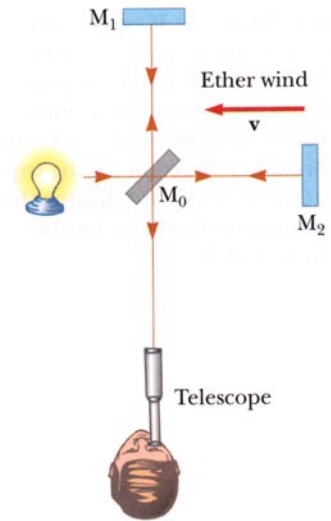

**Figure 26.3** If the speed of the ether wind relative to the Earth is  $v$ , and  $c$  is the speed of light relative to the ether, the speed of light relative to the Earth is (a)  $c + v$  in the downwind direction, (b)  $c - v$  in the upwind direction, and (c)  $(c^2 - v^2)^{1/2}$  in the direction per-

## 26.4 THE MICHELSON–MORLEY EXPERIMENT

The most famous experiment designed to detect small changes in the speed of light was performed in 1887 by A. A. Michelson (1852–1931) and E. W. Morley (1838–1923). We should state at the outset that the outcome of the experiment was *negative*, thus contradicting the ether hypothesis. The experiment was designed to determine the velocity of the Earth with respect to the hypothetical ether. The tool used was the Michelson interferometer, shown in Figure 26.4. When one of the arms of the interferometer was aligned along the direction of the Earth's motion through space, the motion of the Earth through the ether would have been equivalent to the ether flowing past the Earth in the opposite direction. This ether wind blowing in the opposite direction should have caused the speed of light as measured in the Earth's frame of reference to be  $c - v$  as it approached the mirror  $M_2$  in Figure 26.4 and  $c + v$  after reflection. The speed  $v$  is the speed of the Earth through space, and hence the speed of the ether wind, and  $c$  is the speed of light in the absolute ether frame. In the experiment the two beams of light reflected from  $M_1$  and  $M_2$  recombined, and an interference pattern consisting of alternating dark and bright bands or fringes was formed. During the experiment, the interference pattern was observed while the interferometer was rotated through an angle of  $90^\circ$ . The effect of this rotation should have been to cause a slight but measurable shift in the fringe pattern. Measurements failed to show any change in the interference pattern! The Michelson–Morley experiment was repeated by other researchers under various conditions and at different locations, but the results were always the same: **No fringe shift of the magnitude required by the ether hypothesis was ever observed.**

The negative results of the Michelson–Morley experiment meant that it was impossible to measure the absolute orbital velocity of the Earth with respect to the ether frame. However, as we shall see in the next section, Einstein developed a postulate for his theory of relativity that places quite a different interpretation on these results. In later years, when more was known about the nature of light, the idea of an ether that permeates all of space was relegated to the ash heap of worn-out concepts. Light is now understood to be an electromagnetic wave that requires no medium for its propagation. As a result, the idea of having an ether in which electromagnetic waves travel became unnecessary.



**Figure 26.4** According to the ether-wind theory, the speed of light should be  $c - v$  as the beam approaches mirror  $M_2$  and  $c + v$  after reflection.

### Details of the Michelson–Morley Experiment

*Optional Section*

As we mentioned earlier, the Michelson–Morley experiment was designed to detect the motion of the Earth with respect to the ether. Before we examine the details of this important, historical experiment, it is instructive to first consider a race between two airplanes, as shown in Figure 26.5a. One airplane flies from point  $O$  to point  $A$  perpendicular to the direction of the wind, and the second airplane flies from point  $O$  to point  $B$  parallel to the wind. We shall assume that they start at  $O$  at the same time, travel the same distance  $L$  with the same cruising speed  $c$  with respect to the wind, and return to  $O$ . Which airplane will win the race? In order to answer this question, we shall first calculate the time of flight for both airplanes.

First, consider the airplane that moves along path I parallel to the wind. As it moves to the right, its speed is enhanced by the wind, and its velocity with respect

**Figure 26.5** (a) If an airplane wishes to travel from  $O$  to  $A$  with a wind blowing to the right, it must head into the wind at some angle. (b) Vector diagram for determining the airplane's direction for the trip from  $O$  to  $A$ . (c) Vector diagram for determining its direction for the trip from  $A$  to  $O$ .

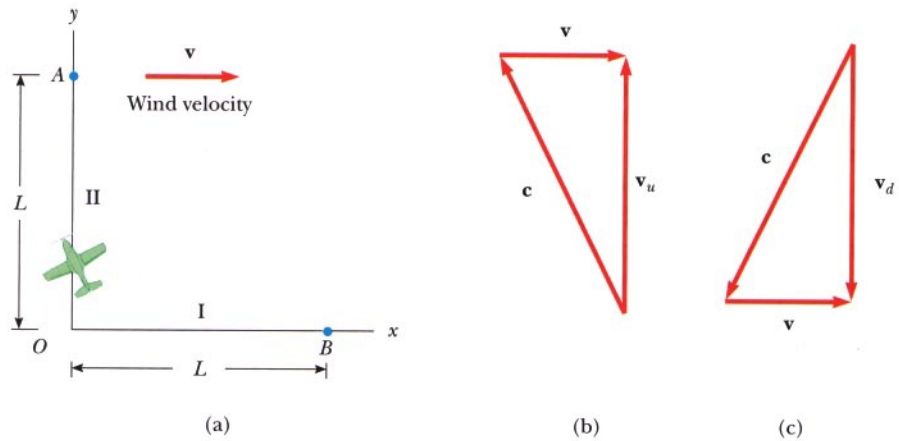

**Albert A. Michelson,**  
German American physicist  
(1852–1931)

Michelson spent much of his life making accurate measurements of the speed of light. In 1907 he was the first American to be awarded the Nobel prize, which he received for his work in optics. His most famous experiment, conducted with Edward Morley in 1887, implied that it was impossible to measure the absolute velocity of the Earth with respect to the ether. (AIP Emilio Segré Visual Archives, Michelson Collection)

to the Earth is  $c + v$ . As it moves to the left on its return journey, it must fly opposite the wind; hence its speed with respect to the Earth is  $c - v$ . Thus, the times of flight to the right and to the left are, respectively,

$$t_R = \frac{L}{c + v} \quad \text{and} \quad t_L = \frac{L}{c - v}$$

and the total time of flight for the airplane moving along path I is

$$\begin{aligned} t_1 &= t_R + t_L = \frac{L}{c + v} + \frac{L}{c - v} = \frac{2Lc}{c^2 - v^2} \\ &= \frac{2L}{c \left(1 - \frac{v^2}{c^2}\right)} \end{aligned} \quad [26.1]$$

Now consider the airplane flying along path II. If the pilot aims the airplane directly toward point  $A$ , it will be blown off course by the wind and will not reach its destination. To compensate for the wind, the pilot must point the airplane into the wind at some angle as shown in Figure 26.5a. This angle must be selected so that the vector sum of  $\mathbf{c}$  and  $\mathbf{v}$  leads to a velocity vector pointed directly toward  $A$ . The resultant vector diagram is shown in Figure 26.5b, where  $\mathbf{v}_u$  is the velocity of the airplane with respect to the ground as it moves from  $O$  to  $A$ . From the Pythagorean theorem, the magnitude of the vector  $\mathbf{v}_u$  is

$$v_u = \sqrt{c^2 - v^2} = c \sqrt{1 - \frac{v^2}{c^2}}$$

Likewise, on the return trip from  $A$  to  $O$ , the pilot must again head into the wind so that the airplane's velocity with respect to the Earth,  $\mathbf{v}_d$ , will be directed toward  $O$ , as shown in Figure 26.5c. From this figure, we see that

$$v_d = \sqrt{c^2 - v^2} = c \sqrt{1 - \frac{v^2}{c^2}}$$

Thus, the total time of flight for the trip along path II is

$$\begin{aligned}
 t_2 &= \frac{L}{v_u} + \frac{L}{v_d} = \frac{L}{c\sqrt{1-\frac{v^2}{c^2}}} + \frac{L}{c\sqrt{1-\frac{v^2}{c^2}}} \\
 &= \frac{2L}{c\sqrt{1-\frac{v^2}{c^2}}} \qquad [26.2]
 \end{aligned}$$

Comparing Equations 26.1 and 26.2, we see that the airplane flying along path II wins the race. The difference in flight times is given by

$$\Delta t = t_1 - t_2 = \frac{2L}{c} \left[ \frac{1}{\left(1 - \frac{v^2}{c^2}\right)} - \frac{1}{\sqrt{1 - \frac{v^2}{c^2}}} \right]$$

This expression can be simplified using the following binomial expansions in  $v/c$  (assumed to be much smaller than 1) after dropping all terms higher than second order:

$$\left(1 - \frac{v^2}{c^2}\right)^{-1} \approx 1 + \frac{v^2}{c^2}$$

and

$$\left(1 - \frac{v^2}{c^2}\right)^{-1/2} \approx 1 + \frac{1}{2} \frac{v^2}{c^2}$$

Therefore, the difference in flight times is

$$\Delta t = \frac{Lv^2}{c^3} \qquad [26.3]$$

The analogy between this airplane race and the Michelson–Morley experiment is shown in Figure 26.6a. Two beams of light travel along two arms of an interferometer. In this case, the “wind” is the ether blowing across the Earth from left to

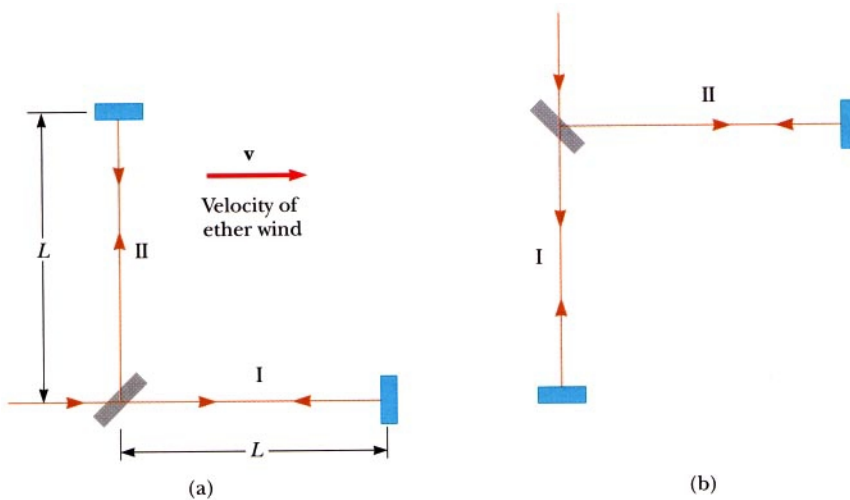

**Figure 26.6** (a) Top view of the Michelson–Morley interferometer, where  $\mathbf{v}$  is the velocity of the ether and  $L$  is the length of each arm. (b) When the interferometer is rotated by  $90^\circ$ , the role of each arm is reversed.



right as the Earth moves through the ether from right to left. Because the speed of the Earth in its orbital path is approximately equal to  $3 \times 10^4$  m/s, the speed of the wind should be at least this great. The two light beams start out in phase and return to form an interference pattern. Let us assume that the interferometer is adjusted for parallel fringes and that a telescope is focused on one of these fringes. The time difference between the two light beams gives rise to a phase difference between the beams, producing an interference pattern when they combine at the position of the telescope. The difference in the pattern is detected by rotating the interferometer through  $90^\circ$  in a horizontal plane, so that the two beams exchange roles (Fig. 26.6b). This results in a net time shift of twice the time difference given by Equation 26.3. Thus, the net time difference is

$$\Delta t_{\text{net}} = 2 \Delta t = \frac{2Lv^2}{c^3} \quad [26.4]$$

The corresponding path difference is

$$\Delta d = c \Delta t_{\text{net}} = \frac{2Lv^2}{c^2} \quad [26.5]$$

In the first experiments by Michelson and Morley, each light beam was reflected by the mirrors many times to give an increased effective path length  $L$  of about 11 meters. Using this value and taking  $v$  to be equal to  $3 \times 10^4$  m/s gives a path difference of

$$\Delta d = \frac{2(11 \text{ m})(3.0 \times 10^4 \text{ m/s})^2}{(3.0 \times 10^8 \text{ m/s})^2} = 2.2 \times 10^{-7} \text{ m}$$

This extra travel distance should produce a noticeable shift in the fringe pattern. Specifically, calculations show that if the pattern is viewed while the interferometer is rotated through  $90^\circ$ , a shift of about 0.4 fringes should be observed. The instrument used by Michelson and Morley was capable of detecting a shift in the fringe pattern as small as 0.01 fringes. However, *they detected no shift in the fringe pattern*. Since then, the experiment has been repeated many times by various scientists under various conditions and no fringe shift has ever been detected. Thus, it was concluded that the motion of the Earth with respect to the ether cannot be detected.

Many efforts were made to explain the null results of the Michelson–Morley experiment. For example, perhaps the Earth drags the ether with it in its motion through space. To test this assumption, interferometer measurements were made at various altitudes, but again no fringe shift was detected. In the 1890s G. F. Fitzgerald and H. A. Lorentz tried to explain the null results by making the following ad hoc assumption. They proposed that the length of an object moving along the direction of the ether wind would contract by a factor of  $\sqrt{1 - v^2/c^2}$ . The net result of this contraction would be a change in length of one of the arms of the interferometer such that no path difference would occur as the interferometer was rotated.

No other experiment in the history of physics has received such valiant efforts to explain the absence of an expected result as has the Michelson–Morley experiment. The stage was set for the brilliant Albert Einstein, who solved the problem in 1905 with his special theory of relativity.

## 26.5 EINSTEIN'S PRINCIPLE OF RELATIVITY

In the previous section we noted the serious contradiction between the Newtonian addition law for velocities and the fact that the speed of light is the same for all observers. In 1905 Albert Einstein proposed a theory that would resolve this contradiction but at the same time would completely alter our notions of space and time. Einstein based his special theory of relativity on the following general hypothesis, which is called the **principle of relativity**:

**All the laws of physics are the same in all inertial frames.**

An immediate consequence of the principle of relativity is that

**The speed of light in a vacuum has the same value,  $c = 2.997\,924\,58 \times 10^8$  m/s, in all inertial reference frames.**

In other words, anyone who measures the speed of light will get the same value,  $c$ . This implies that the ether does not exist. Together, the principle of relativity and its immediate consequence are often referred to as the two postulates of special relativity.

The null result of the Michelson–Morley experiment can be readily understood within the framework of Einstein's theory. According to his principle of relativity, the premises of the Michelson–Morley experiment were incorrect. In the process of trying to explain the expected results, we stated that when light traveled against the ether wind its speed was  $c - v$ . However, if the state of motion of the observer or of the source has no influence on the value found for the speed of light, the measured value will always be  $c$ . Likewise, the light makes the return trip after reflection from the mirror at a speed of  $c$ , not the speed of  $c + v$ . Thus, the motion of the Earth should not influence the fringe pattern observed in the Michelson–Morley experiment and a null result should be expected.

If we accept Einstein's theory of relativity, we must conclude that relative motion is unimportant when measuring the speed of light. At the same time, we must alter our common-sense notions of space and time and be prepared for some rather bizarre consequences.

## 26.6 CONSEQUENCES OF SPECIAL RELATIVITY

Almost everyone who has dabbled even superficially in science is aware of some of the startling predictions that arise because of Einstein's approach to relative motion. As we examine some of the consequences of relativity in this section, we shall find that they conflict with some of our basic notions of space and time. We shall restrict our discussion to the concepts of length, time, and simultaneity, which are quite different in relativistic mechanics from what they are in Newtonian mechanics. For example, we shall see that the distance between two points and the time interval

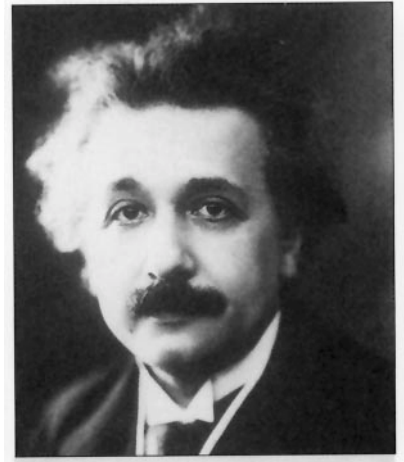

**Albert Einstein** (1879–1955)

Einstein, one of the greatest physicists of all times, was born in Ulm, Germany. In 1905, at the age of 26, he published four scientific papers that revolutionized physics. Two of these papers were concerned with what is now considered his most important contribution: the special theory of relativity. In 1916, Einstein published his work on the general theory of relativity. The most dramatic prediction of this theory is the degree to which light is deflected by a gravitational field. Measurements made by astronomers on bright stars in the vicinity of the eclipsed sun in 1919 confirmed Einstein's prediction, and as a result Einstein became a world celebrity. Einstein was deeply disturbed by the development of quantum mechanics in the 1920s despite his own role as a scientific revolutionary. In particular, he could never accept the probabilistic view of events in nature that is a central feature of quantum theory. The last few decades of his life were devoted to an unsuccessful search for a unified theory that would combine gravitation and electromagnetism. (*AIP Niels Bohr Library*)

Absolute length and absolute time intervals are meaningless in relativity. ►

between two events depend on the frame of reference in which they are measured. That is, in relativity, there is no such thing as absolute length or absolute time. Furthermore, events at different locations that occur simultaneously in one frame are not simultaneous in another frame.

### Simultaneity and the Relativity of Time

A basic premise of Newtonian mechanics is that there is a universal time scale that is the same for all observers. In fact, Newton wrote, “Absolute, true, and mathematical time, of itself, and from its own nature, flows equably without relation to anything external.” In his special theory of relativity, Einstein abandoned this assumption. According to Einstein, **time interval measurements depend on the reference frame in which they are made.**

Einstein devised the following thought experiment to illustrate this point. A boxcar moves with uniform velocity, and two lightning bolts strike its ends, as in Figure 26.7a, leaving marks on the boxcar and the ground. The marks left on the boxcar are labeled  $A'$  and  $B'$ , and those on the ground are labeled  $A$  and  $B$ . An observer at  $O'$  moving with the boxcar is midway between  $A'$  and  $B'$ , and an observer on the ground at  $O$  is midway between  $A$  and  $B$ . The events recorded by the observers are the light signals from the lightning bolts.

Let us assume that the two light signals reach the observer at  $O$  at the same time, as indicated in Figure 26.7b. This observer realizes that the light signals have traveled at the same speed over distances of equal length. Thus, the observer at  $O$  concludes that the events at  $A$  and  $B$  occurred simultaneously. Now consider the same events as viewed by the observer on the boxcar at  $O'$ . By the time the light has reached the observer at  $O$ , the observer at  $O'$  has moved, as indicated in Figure 26.7b. Thus, the light signal from  $B'$  has already swept past  $O'$ , whereas the light from  $A'$  has not yet reached  $O'$ . According to Einstein’s second postulate, the observer at  $O'$  must find that light travels at the same speed as that measured by the observer at  $O$ . Therefore, the observer at  $O'$  concludes that the lightning struck the front of the boxcar before it struck the back. This thought experiment clearly dem-

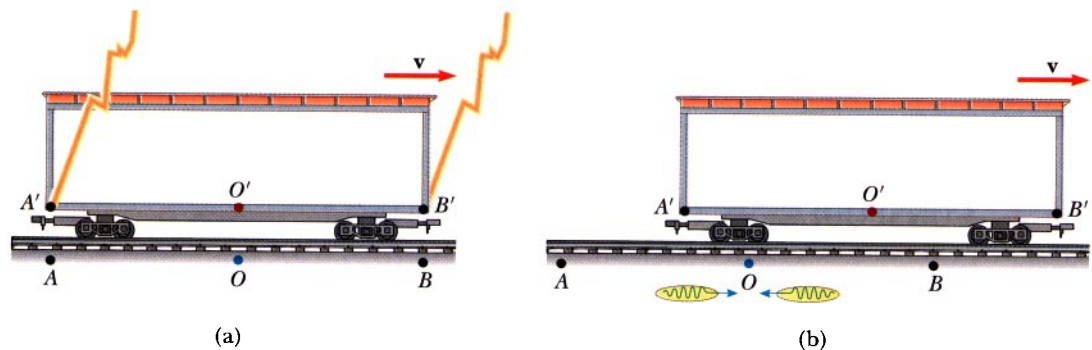

**Figure 26.7** Two lightning bolts strike the ends of a moving boxcar. (a) The events appear to be simultaneous to the stationary observer at  $O$ , who is midway between  $A$  and  $B$ . (b) The events do not appear to be simultaneous to the observer at  $O'$ , who claims that the front of the train is struck *before* the rear.

onstrates that the two events that appear to be simultaneous to the observer at  $O$  do not appear to be simultaneous to the observer at  $O'$ . In other words,

**Two events that are simultaneous in one reference frame are in general not simultaneous in a second frame moving with respect to the first. That is, simultaneity is not an absolute concept.**

At this point, you might wonder which observer is right concerning the two events. The answer is that both are correct because the principle of relativity states that **there is no preferred inertial frame of reference**. Although the two observers reach different conclusions, both are correct in their own reference frames because the concept of simultaneity is not absolute.

### Time Dilation

Consider a vehicle moving to the right with a speed  $v$ , as in Figure 26.8a. A perfectly reflecting mirror is fixed to the ceiling of the vehicle, and an observer at  $O'$  at rest in this system holds a flash gun a distance  $d$  below the mirror. At some instant, the flash gun goes off and a pulse of light is released. Because the light pulse has a speed  $c$ , the time it takes it to travel from the observer to the mirror and back again can be found from the definition of velocity,

$$\Delta t_p = \frac{\text{distance traveled}}{\text{velocity}} = \frac{2d}{c} \quad [26.6]$$

where  $\Delta t_p$  is the time interval measured by  $O'$ , the observer who is at rest in the moving vehicle.

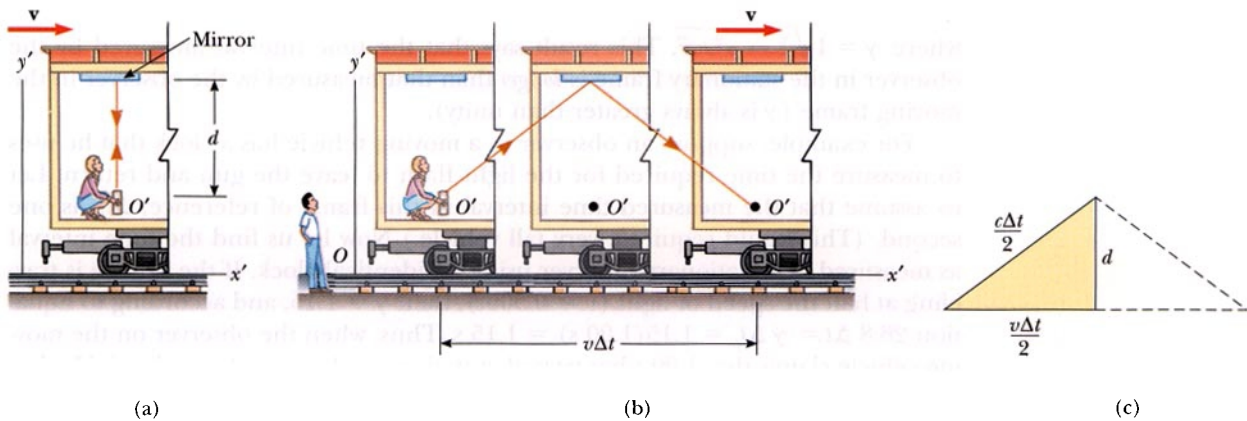

**Figure 26.8** (a) A mirror is fixed to a moving vehicle, and a light pulse leaves  $O'$  at rest in the vehicle. (b) Relative to a stationary observer on Earth, the mirror and  $O'$  move with a speed  $v$ . Note that the distance the pulse travels is greater than  $2d$  as measured by the stationary observer. (c) The right triangle for calculating the relationship between  $\Delta t$  and  $\Delta t_p$ .

Now consider the same set of events as viewed by an observer at  $O$  in a stationary frame (Fig. 26.8b). According to this observer, the mirror and flash gun are moving to the right with a speed of  $v$ . The sequence of events just described would appear entirely different to this stationary observer. By the time the light from the flash gun reaches the mirror, the mirror will have moved a distance of  $v \Delta t/2$ , where  $\Delta t$  is the time it takes the light pulse to travel from  $O'$  to the mirror and back, as measured by the stationary observer. In other words, the stationary observer concludes that, because of the motion of the system, the light, if it is to hit the mirror, will leave the flash gun at an angle with respect to the vertical. Comparing Figures 26.8a and 26.8b, we see that the light must travel farther in the stationary frame than in the moving frame.

Now, according to Einstein's second postulate, the speed of light must be  $c$  as measured by both observers. Therefore, it follows that the time interval  $\Delta t$ , measured by the observer in the stationary frame, is *longer* than the time interval  $\Delta t_p$ , measured by the observer in the moving frame. To obtain a relationship between  $\Delta t$  and  $\Delta t_p$ , it is convenient to use the right triangle shown in Figure 26.8c. The Pythagorean theorem applied to this triangle gives

$$\left(\frac{c \Delta t}{2}\right)^2 = \left(\frac{v \Delta t}{2}\right)^2 + d^2$$

Solving for  $\Delta t$  gives

$$\Delta t = \frac{2d}{\sqrt{c^2 - v^2}} = \frac{2d}{c\sqrt{1 - v^2/c^2}} \quad [26.7]$$

Because  $\Delta t_p = 2d/c$ , we can express Equation 26.7 as

$$\text{Time dilation} \quad \Delta t = \frac{\Delta t_p}{\sqrt{1 - v^2/c^2}} = \gamma \Delta t_p \quad [26.8]$$

where  $\gamma = 1/\sqrt{1 - v^2/c^2}$ . This result says that the time interval measured by the observer in the stationary frame is *longer* than that measured by the observer in the moving frame ( $\gamma$  is always greater than unity).

For example, suppose an observer in a moving vehicle has a clock that he uses to measure the time required for the light flash to leave the gun and return. Let us assume that the measured time interval in this frame of reference,  $\Delta t_p$ , is one second. (This would require a very tall vehicle.) Now let us find the time interval as measured by a stationary observer using an identical clock. If the vehicle is traveling at half the speed of light ( $v = 0.500c$ ), then  $\gamma = 1.15$ , and according to Equation 26.8  $\Delta t = \gamma \Delta t_p = 1.15(1.00 \text{ s}) = 1.15 \text{ s}$ . Thus, when the observer on the moving vehicle claims that 1.00 s has passed, a stationary observer claims that 1.15 s has passed. From this we may conclude that,

A clock in motion runs more slowly than an identical stationary clock. ►

**According to a stationary observer, a moving clock runs more slowly than an identical stationary clock by a factor of  $\gamma^{-1}$ . This effect is known as **time dilation**.**

The time interval  $\Delta t_p$  in Equation 26.8 is called the *proper time*. In general, **proper time** is defined as **the time interval between two events as measured by an observer who sees the events occur at the same place**. In our case, the observer at  $O'$  measures the proper time. That is, **proper time is always the time interval measured with a single clock at rest in the frame in which the events take place at the same position**.

We have seen that moving clocks run slow by a factor of  $\gamma^{-1}$ . This is true for ordinary mechanical clocks as well as for the light clock just described. In fact, we can generalize these results by stating that **all physical processes, including chemical and biological reactions, slow down relative to a stationary clock when they occur in a moving frame**. For example, the heartbeat of an astronaut moving through space has to keep time with a clock inside the spaceship. Both the spaceship clock and the heartbeat are slowed down relative to a stationary clock. The astronaut would not, however, have any sensation of life slowing down in the spaceship.

Time dilation is a very real phenomenon that has been verified by various experiments. *Muons* are unstable elementary particles with a charge equal to that of the electron and a mass 207 times that of the electron. They can be produced by the absorption of cosmic radiation high in the atmosphere. These unstable particles have a lifetime of only  $2.2 \mu\text{s}$  when measured in a reference frame at rest with respect to them. If we take  $2.2 \mu\text{s}$  as the average lifetime of a muon and assume that their speed is close to the speed of light, we find that these particles can travel only about 600 m before they decay (Fig. 26.9a). Hence, they could never reach the Earth from the upper atmosphere where they are produced. However, experiments show that a large number of muons *do* reach the Earth, and the phenomenon of time dilation explains how. Relative to an observer on Earth, the muons have a lifetime equal to  $\gamma\tau_p$ , where  $\tau_p = 2.2 \mu\text{s}$  is the lifetime in a frame of reference traveling with the muons. For example, for  $v = 0.99c$ ,  $\gamma \approx 7.1$  and  $\gamma\tau \approx 16 \mu\text{s}$ . Hence, the average distance traveled as measured by an observer on Earth is  $\gamma v\tau \approx 4800 \text{ m}$ , as indicated in Figure 26.9b.

In 1976 experiments with muons were conducted at the laboratory of the European Council for Nuclear Research (CERN) in Geneva. Muons were injected into a large storage ring, reaching speeds of about  $0.9994c$ . Electrons produced by the decaying muons were detected by counters around the ring, enabling scientists to measure the decay rate, and hence the lifetime of the muons. The lifetime of the moving muons was measured to be about 30 times as long as that of stationary muons to within two parts in a thousand, in agreement with the prediction of relativity.

The results of an experiment reported by Hafele and Keating provided direct evidence for the phenomenon of time dilation.<sup>2</sup> The experiment involved the use of very stable cesium-beam atomic clocks. Time intervals measured with four such clocks in jet flight were compared with time intervals measured by reference atomic clocks at the U.S. Naval Observatory. (Because of the Earth's rotation about its axis, a ground-based clock is not in a true inertial frame.) Time intervals measured with the flying clocks were compared to time intervals measured with the Earth-based reference clocks. In order to compare the results with the theory, many factors had to be considered, including periods of acceleration and deceleration relative to the

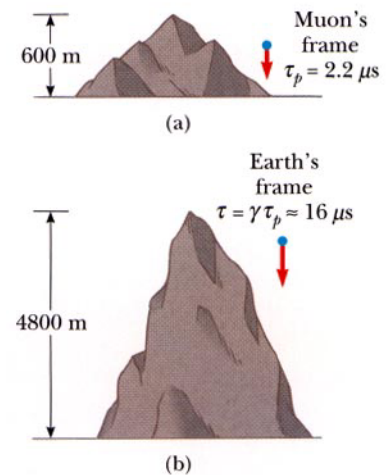

**Figure 26.9** (a) The muons travel only about 600 m as measured in the muons' reference frame, in which their lifetime is about  $2.2 \mu\text{s}$ . Because of time dilation, the muons' lifetime is longer as measured by the observer on Earth. (b) Muons traveling with a speed of  $0.99c$  travel a distance of about 4800 m as measured by an observer on Earth.

<sup>2</sup> J. C. Hafele and R. E. Keating, "Around the World Atomic Clocks: Relativistic Time Gains Observed," *Science*, July 14, 1972, p. 168.

Earth, variations in direction of travel, and the weaker gravitational field experienced by the flying clocks. Their results were in good agreement with the predictions of the special theory of relativity. In their paper, Hafele and Keating report the following: “Relative to the atomic time scale of the U.S. Naval Observatory, the flying clocks lost  $59 \pm 10$  ns during the eastward trip and gained  $273 \pm 7$  ns during the westward trip. . . . These results provide an unambiguous empirical resolution of the famous clock paradox with macroscopic clocks.”

### Thinking Physics 2

Suppose a student explains time dilation with the following argument: If you start running at  $0.99c$  away from a clock at 12:00, you would not see the time change, because the light from the clock representing 12:01 would never reach you. What is the flaw in this argument?

**Explanation** The inference in this argument is that the velocity of light relative to the runner is approximately zero — “the light . . . would never reach you.” This is a Newtonian relativity point of view, in which the relative velocity is a simple subtraction of running velocity from the light velocity. From the point of view of special relativity, one of the fundamental postulates is that the speed of light is the same for all observers, including one running away from the light source at the speed of light. Thus, the light from 12:01 will move toward the runner at the speed of light.

#### EXAMPLE 26.1 What Is the Period of the Pendulum?

The period of a pendulum is measured to be  $3.0$  s in the inertial frame of the pendulum. What is the period when measured by an observer moving at a speed of  $0.95c$  with respect to the pendulum?

**Reasoning and Solution** In this case, the proper time is  $3.0$  s. We can use Equation 26.8 to calculate the period measured by the moving observer:

$$T = \gamma T_p = \frac{1}{\sqrt{1 - \frac{(0.95c)^2}{c^2}}} T_p = (3.2)(3.0 \text{ s}) = 9.6 \text{ s}$$

That is, the observer moving with a speed of  $0.95c$  observes that the pendulum slows down.

### The Twin Paradox

An interesting consequence of time dilation is the so-called twin paradox. Consider a controlled experiment involving 20-year-old twin brothers Speedo and Goslo (Fig. 26.10). Speedo, the more adventuresome twin, sets out on a journey toward a star located 30 lightyears from Earth. His spaceship is able to accelerate to a speed close to the speed of light. After reaching the star, Speedo becomes very homesick and immediately returns to Earth at the same high speed. On his return, he is shocked to find that many things have changed. Old cities have expanded and new cities have appeared. Lifestyles, fashions, and transportation systems have changed dramatically. Speedo’s twin brother, Goslo, has aged to about 80 years old and is now

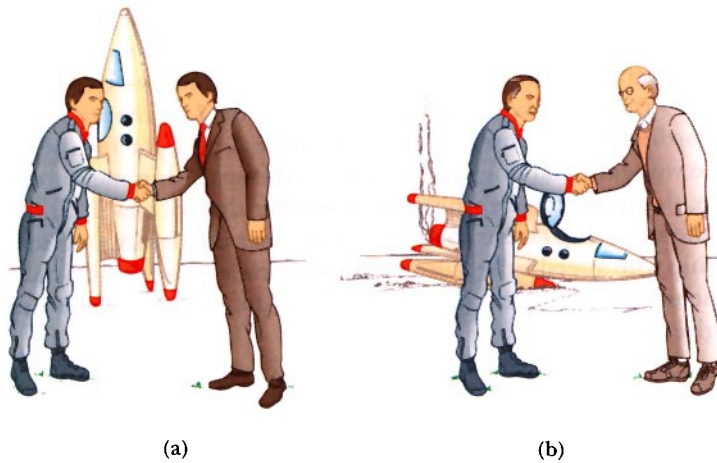

**Figure 26.10** (a) As the twins depart, they are the same age. (b) When Speedo returns from his journey to Planet X, he is younger than his twin Goslo who remained on Earth.

wiser, feeble, and somewhat hard of hearing. Speedo, on the other hand, has aged only about 10 years. This is because his bodily processes slowed down during his travels in space.

It is quite natural to raise the question, “Which twin actually travels at a speed close to the speed of light, and therefore does not age as much?” Herein lies the paradox: From Goslo’s frame of reference, he is at rest while his brother Speedo travels at a high velocity. On the other hand, according to the space traveler Speedo, it is he who is at rest while his brother zooms away from him on Earth and then returns. This leads to confusion about which twin actually ages more.

In order to resolve this paradox, it should be pointed out that the trip is not as symmetrical as we may have led you to believe. Speedo, the space traveler, experiences a series of accelerations and decelerations during his journey to the star and back home, and therefore is not always in uniform motion. This means that Speedo is in a noninertial frame during part of his trip, so that predictions based on special relativity are not valid in his frame. On the other hand, the brother on Earth is in an inertial frame and can make reliable predictions based on the special theory. The situation is not symmetrical because Speedo experiences accelerations when his spaceship turns around, whereas Goslo is not subject to such accelerations. Therefore, the space traveler is indeed younger on returning to Earth.

◀ The space traveler ages more slowly than his twin who remains on Earth.

## Length Contraction

We have seen that measured time intervals are not absolute—that is, the time interval between two events depends on the frame of reference in which it is measured. Likewise, the measured distance between two points depends on the frame of reference. The **proper length** of an object is defined as **the length of the object measured in the reference frame in which the object is at rest**. The length of an object measured in a reference frame in which the object is moving is always less than the proper length. This effect is known as **relativistic length contraction**.



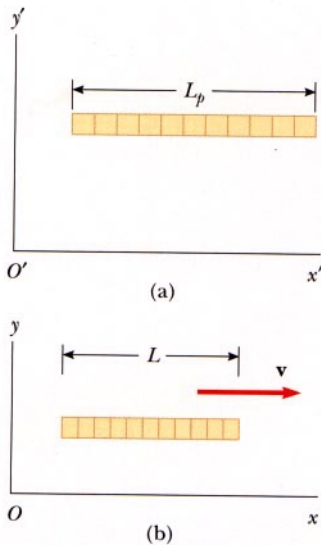

**Figure 26.11** A meter stick moves to the right with a speed  $v$ . (a) The meter stick as viewed by an observer at rest with respect to the meter stick. (b) The meter stick as seen by an observer moving with a speed  $v$  with respect to the meter stick. The moving meter stick is always measured to be *shorter* than in its own rest frame by a factor of  $\sqrt{1 - v^2/c^2}$ .

### APPLICATION

Passage of Time in Space Travel.

To understand relativistic length contraction quantitatively, let us consider a spaceship traveling with a speed  $v$  from one star to another, as seen by two observers. An observer at rest on Earth (and also assumed to be at rest with respect to the two stars) measures the distance between the stars to be  $L_p$  (where  $L_p$  is the proper length). According to this observer, it takes a time  $\Delta t = L_p/v$  for the spaceship to complete the voyage. What does an observer in the spaceship measure? Because of time dilation, the space traveler measures a smaller time of travel:  $\Delta t_p = \Delta t/\gamma$ . The observer in the spaceship claims to be at rest and sees the destination star as moving toward the ship with speed  $v$ . Because the space traveler reaches the star in the time  $\Delta t_p$ , she concludes that the distance,  $L$ , between the stars is shorter than  $L_p$ . This distance is given by

$$L = v \Delta t_p = v \frac{\Delta t}{\gamma}$$

Because  $L_p = v \Delta t$ , we see that

$$L = \frac{L_p}{\gamma}$$

or,

$$\text{Length contraction} \quad \blacktriangleright \quad L = L_p \sqrt{1 - v^2/c^2} \quad [26.9]$$

According to this result, illustrated in Figure 26.11, if an observer at rest with respect to an object measures its length to be  $L_p$ , an observer moving at a relative speed  $v$  with respect to the object will find it to be shorter than its rest length by the factor  $\sqrt{1 - v^2/c^2}$ . You should note that **the length contraction takes place only along the direction of motion.**

Time dilation and length contraction effects have interesting applications for future space travel to distant stars. In order for the star to be reached in a reasonable fraction of a human lifetime, the trip must be taken at very high speeds. According to an Earth-bound observer, the time for a spacecraft to reach the destination star will be dilated compared to the time interval measured by the travelers. Thus, it will seem to the travelers to take less time to reach the star than for the Earth-bound observers, as was discussed in the treatment of the twin paradox. We can also argue this from length contraction. For the travelers, the distance from Earth to the star will appear to be contracted, and it will consequently take less time to cover this shorter distance. Thus, by the time the travelers reach the star, they have aged by some number of years, while their partners back on Earth will have aged a larger number of years, the exact ratio depending on the speed of the spacecraft. At a spacecraft speed of  $0.94c$ , this ratio is about 3:1.

Another consideration for the space travelers is related to their paychecks. You are invited to explore this issue in Conceptual Question 3.

### EXAMPLE 26.2 The Contraction of a Spaceship

A spaceship is measured to be 120 m long while it is at rest with respect to an observer. If this spaceship now flies past the observer with a speed of  $0.99c$ , what length will the observer measure for the spaceship?

**Solution** From Equation 26.9, the length measured by the observer is

$$L = L_p \sqrt{1 - v^2/c^2} = (120 \text{ m}) \sqrt{1 - \frac{(0.99c)^2}{c^2}} = 17 \text{ m}$$

**Exercise** If the ship moves past the observer with a speed of  $0.01000c$ , what length will the observer measure?

**Answer** 119.994 m

### EXAMPLE 26.3 How High Is the Spaceship?

An observer on Earth sees a spaceship at an altitude of 435 m moving downward toward the Earth with a speed of  $0.970c$ . What is the altitude of the spaceship as measured by an observer in the spaceship?

**Solution** The moving observer in the spaceship finds the altitude to be

$$L = L_p \sqrt{1 - v^2/c^2} = (435 \text{ m}) \sqrt{1 - \frac{(0.970c)^2}{c^2}} = 106 \text{ m}$$

### EXAMPLE 26.4 The Triangular Spaceship

A spaceship in the form of a triangle flies by an observer with a speed of  $0.95c$ . When the spaceship is at rest (Fig. 26.12a), the distances  $x$  and  $y$  are found to be 52 m and 25 m, respectively. What is the shape of the spaceship as seen by an observer at rest when the spaceship is in motion along the direction shown in Figure 26.12b?

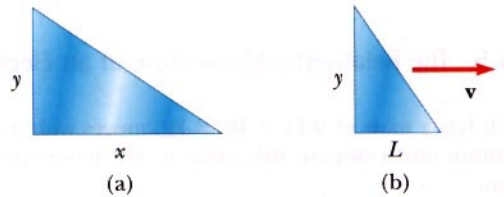

**Figure 26.12** (Example 26.4) (a) When the spaceship is at rest, its shape is as shown. (b) The spaceship appears to look like this when it moves to the right with a speed  $v$ . Note that only its  $x$  dimension is contracted in this case.

**Solution** The observer sees the horizontal length of the spaceship to be contracted to a length of

$$L = L_p \sqrt{1 - v^2/c^2} = (52 \text{ m}) \sqrt{1 - \frac{(0.95c)^2}{c^2}} = 16 \text{ m}$$

The 25-m vertical height is unchanged because it is perpendicular to the direction of relative motion between the observer and the spaceship. Figure 26.12b represents the shape of the spaceship as seen by the observer at rest.

## 26.7 RELATIVISTIC MOMENTUM

In order to describe properly the motion of particles within the framework of special relativity, we must generalize Newton's laws of motion and the definitions of momentum and energy. As we shall see, these generalized definitions reduce to the classical (nonrelativistic) definitions when  $v$  is much less than  $c$ .

First, recall that conservation of momentum states that when two objects collide, the total momentum of the system remains constant, assuming that the objects are isolated (that is, they interact only with each other). If such a collision is analyzed within the framework of Einstein's postulates of relativity, it is found that momentum is not conserved if the classical definition of momentum,  $p = mv$ , is used. However, according to the principle of relativity, momentum must be conserved in all reference systems. In view of this condition, it is necessary to modify the definition of momentum to satisfy the following conditions:

1. The relativistic momentum must be conserved in all collisions.
2. The relativistic momentum must approach the classical value  $mv$  as the quantity  $v/c$  approaches zero.

The correct relativistic equation for momentum that satisfies these conditions is

Momentum ►

$$p \equiv \frac{mv}{\sqrt{1 - v^2/c^2}} = \gamma mv \quad [26.10]$$

where  $v$  is the velocity of the particle. The theoretical derivation of this generalized expression for momentum is beyond the scope of this text. Note that when  $v$  is much less than  $c$ , the denominator of Equation 26.10 approaches unity, so that  $p$  approaches  $mv$ . Therefore, the relativistic equation for momentum reduces to the classical expression when  $v$  is small compared with  $c$ . When the speed of an object is less than  $0.1c$ , the classical expression  $mv$  will be equal to its actual (relativistic) momentum within 0.5% or better.

### EXAMPLE 26.5 The Relativistic Momentum of an Electron

An electron, which has a mass of  $9.11 \times 10^{-31}$  kg, moves with a speed of  $0.75c$ . Find its relativistic momentum and compare this value to the momentum calculated from the classical expression.

**Solution** From Equation 26.10, with  $v = 0.75c$ , we have

$$\begin{aligned} p &= \frac{mv}{\sqrt{1 - v^2/c^2}} \\ &= \frac{(9.11 \times 10^{-31} \text{ kg})(0.75 \times 3.00 \times 10^8 \text{ m/s})}{\sqrt{1 - (0.75c)^2/c^2}} = 3.1 \times 10^{-22} \text{ kg} \cdot \text{m/s} \end{aligned}$$

The classical expression gives

$$\text{Momentum} = mv = 2.1 \times 10^{-22} \text{ kg} \cdot \text{m/s}$$

The (correct) relativistic result is 50% greater than the classical result!

## 26.8 RELATIVISTIC ADDITION OF VELOCITIES

Imagine a motorcycle rider moving with a speed of  $0.80c$  past a stationary observer, as shown in Figure 26.13. If the rider tosses a ball in the forward direction with a speed of  $0.70c$  relative to himself, what is the speed of the ball as seen by the stationary observer at the side of the road? Common sense and the ideas of Newtonian relativity say that the speed should be the sum of the two speeds, or  $1.50c$ . This answer must be incorrect because it contradicts the assertion that no material object can travel faster than the speed of light.

Einstein resolved this dilemma by deriving an equation for the relativistic addition of velocities. For one-dimensional motion, this equation is

$$v_{ab} = \frac{v_{ad} + v_{db}}{1 + \frac{v_{ad}v_{db}}{c^2}} \quad [26.11] \quad \blacktriangleleft \text{Velocity addition}$$

The left side of this equation and the numerator on the right are like the equations of Newtonian relativity discussed in Chapter 3, and the evaluation of subscripts is applied in the same fashion as discussed in Section 3.6. The denominator of Equation 26.11 is a correction to ordinary Newtonian relativity based on length contraction and time dilation. Let us apply this equation to the case of the speedy motorcycle rider and the stationary observer.

We have

$v_{bm}$  = the velocity of the ball with respect to the motorcycle =  $0.70c$ ,

$v_{mo}$  = the velocity of the motorcycle with respect to the stationary observer =  $0.80c$ ,

and we want to find

$v_{bo}$  = the velocity of the ball with respect to the stationary observer.

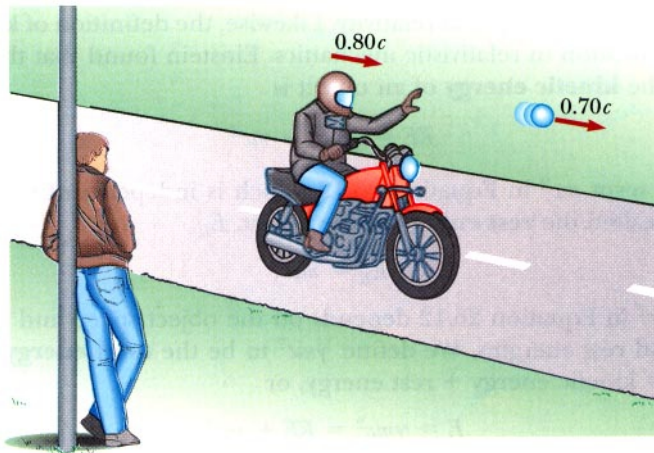

**Figure 26.13** A motorcycle moves past a stationary observer with a speed of  $0.80c$ ; the motorcyclist throws a ball in the direction of motion with a speed of  $0.70c$  relative to himself.



The speed of light is the speed limit of the Universe.

Thus,

$$v_{bo} = \frac{v_{bm} + v_{mo}}{1 + \frac{v_{bm}v_{mo}}{c^2}} = \frac{0.70c + 0.80c}{1 + \frac{(0.70c)(0.80c)}{c^2}} = 0.96c$$

### EXAMPLE 26.6 Measuring the Speed of a Light Beam

Suppose that the motorcyclist moving with a speed of  $0.80c$  turns on beam of light that moves away from the motorcycle with a speed of  $c$  in the same direction as the moving motorcycle. What speed would the stationary observer measure for the beam of light?

**Solution** In this case, we have

$v_{lm}$  = the velocity of the light with respect to the motorcycle =  $c$

$v_{mo}$  = the velocity of the motorcycle with respect to the stationary observer =  $0.80c$

and we want

$v_{lo}$  = the velocity of the light with respect to the stationary observer

Thus,

$$v_{lo} = \frac{v_{lm} + v_{mo}}{1 + \frac{v_{lm}v_{mo}}{c^2}} = \frac{c + 0.80c}{1 + \frac{(c)(0.80c)}{c^2}} = c$$

This is consistent with the statement made earlier that **all observers measure the speed of light to be  $c$  regardless of the motion of the source of light.**

## 26.9 RELATIVISTIC ENERGY

We have seen that the definition of momentum required generalization to make it compatible with the principle of relativity. Likewise, the definition of kinetic energy requires modification in relativistic mechanics. Einstein found that the correct expression for the **kinetic energy** of an object is

$$\text{Kinetic energy} \blacktriangleright \quad KE = \gamma mc^2 - mc^2 \quad [26.12]$$

The constant term  $mc^2$  in Equation 26.12, which is independent of the speed of the object, is called the **rest energy** of the object,  $E_R$ .

$$\text{Rest energy} \blacktriangleright \quad E_R = mc^2 \quad [26.13]$$

The term  $\gamma mc^2$  in Equation 26.12 depends on the object speed and is the sum of the kinetic and rest energies. We define  $\gamma mc^2$  to be the **total energy**,  $E$ —that is, total energy = kinetic energy + rest energy, or

$$E = \gamma mc^2 = KE + mc^2 \quad [26.14]$$

Because  $\gamma = (1 - v^2/c^2)^{-1/2}$ , we can express  $E$  as

$$\text{Total energy} \blacktriangleright \quad E = \frac{mc^2}{\sqrt{1 - v^2/c^2}} \quad [26.15]$$

This, of course, is Einstein's famous mass-energy equivalence equation. The relation  $E = \gamma mc^2 = \gamma E_R$  shows that **mass is one possible manifestation of energy**. Furthermore, this result shows that a small mass corresponds to an enormous amount of energy. This concept is fundamental to much of the field of nuclear physics.

In many situations, the momentum or energy of a particle is measured rather than its speed. It is therefore useful to have an expression relating the total energy  $E$  to the relativistic momentum  $p$ . This is accomplished by using the expressions  $E = \gamma mc^2$  and  $p = \gamma mv$ . By squaring these equations and subtracting, we can eliminate  $v$ . The result, after some algebra, is

$$E^2 = p^2 c^2 + (mc^2)^2 \quad [26.16]$$

When the particle is at rest,  $p = 0$ , and so  $E = E_R = mc^2$ . That is, the total energy equals the rest energy. For the case of particles that have zero mass, such as photons (massless, chargeless particles of light), we set  $m = 0$  in Equation 26.16, and we see that

$$E = pc \quad [26.17]$$

This equation is an exact expression relating energy and momentum for photons, which always travel at the speed of light.

Finally, note that because the mass  $m$  of a particle is independent of its motion,  $m$  must have the same value in all reference frames. For this reason,  $m$  is often called the **invariant mass**. On the other hand, the total energy and momentum of a particle depend on the reference frame in which they are measured, because they both depend on velocity. Because  $m$  is a constant, according to Equation 26.16 the quantity  $E^2 - p^2 c^2$  must have the same value in all reference frames.

When dealing with subatomic particles, it is convenient to express their energy in electron volts (eV), because the particles are usually given this energy by acceleration through an electrostatic potential difference. The conversion factor is

$$1 \text{ eV} = 1.60 \times 10^{-19} \text{ J}$$

For example, the mass of an electron is  $9.11 \times 10^{-31} \text{ kg}$ . Hence, the rest energy of the electron is

$$m_e c^2 = (9.11 \times 10^{-31} \text{ kg})(3.00 \times 10^8 \text{ m/s})^2 = 8.20 \times 10^{-14} \text{ J}$$

Converting this to eV, we have

$$m_e c^2 = (8.20 \times 10^{-14} \text{ J})(1 \text{ eV}/1.60 \times 10^{-19} \text{ J}) = 0.511 \text{ MeV}$$

### Thinking Physics 3

A common principle learned in chemistry is conservation of mass. In practice, if the mass of the reactants is measured before a reaction and the mass of the products is measured afterward, the results will be the same. In light of special relativity, should we stop teaching the principle of conservation of mass in chemistry classes?

**Explanation** Consider a reaction that does not require energy input to occur. This type of reaction occurs because the products represent a lower overall rest energy than the reactants; the difference in rest energy is carried as kinetic energy of ejected particles or radiation. Because the rest energy of the reactants is smaller, according to

relativity the mass of the reactants should be smaller than that of the products. Thus the law of conservation of mass is violated. The mass changes are so small, however, that in practice the law of conservation of mass is still useful.

### EXAMPLE 26.7 The Energy Contained in a Baseball

If a 0.50-kg baseball could be converted completely to energy of forms other than mass, how much energy of other forms would be released?

**Solution** The energy equivalent of the baseball is found from Equation 26.14 (with  $KE = 0$ ):

$$E = E_R = mc^2 = (0.50 \text{ kg})(3.0 \times 10^8 \text{ m/s})^2 = 4.5 \times 10^{16} \text{ J}$$

This is enough energy to keep a 100-W lightbulb burning for approximately ten million years. However, it is generally impossible to achieve complete conversion from mass to energy of other forms. For example, mass is converted to energy in nuclear power plants, but only a small fraction of the mass actually undergoes conversion.

### EXAMPLE 26.8 The Energy of a Speedy Electron

An electron moves with a speed of  $v = 0.850c$ . Find its total energy and kinetic energy in electron volts.

**Solution** The fact that the rest energy of an electron is 0.511 MeV, along with Equation 26.15, gives

$$\begin{aligned} E &= \frac{m_e c^2}{\sqrt{1 - v^2/c^2}} = \frac{0.511 \text{ MeV}}{\sqrt{1 - \frac{(0.850c)^2}{c^2}}} \\ &= 1.90(0.511 \text{ MeV}) = 0.970 \text{ MeV} \end{aligned}$$

The kinetic energy is obtained by subtracting the rest energy from the total energy:

$$KE = E - m_e c^2 = 0.970 \text{ MeV} - 0.511 \text{ MeV} = 0.459 \text{ MeV}$$

### EXAMPLE 26.9 The Energy of a Speedy Proton

The total energy of a proton is three times its rest energy.

(a) Find the proton's rest energy in electron volts.

**Solution** The rest energy is given by Equation 26.13:

$$\begin{aligned} E_R &= m_p c^2 = (1.67 \times 10^{-27} \text{ kg})(3.00 \times 10^8 \text{ m/s})^2 \\ &= (1.50 \times 10^{-10} \text{ J}) \left( \frac{1 \text{ eV}}{1.60 \times 10^{-19} \text{ J}} \right) = 938 \text{ MeV} \end{aligned}$$

(b) With what speed is the proton moving?

**Solution** Because the total energy,  $E$ , is three times the rest energy, Equation 26.14 gives

$$E = \gamma m_p c^2 = 3m_p c^2 = \frac{m_p c^2}{\sqrt{1 - v^2/c^2}}$$

$$3 = \frac{1}{\sqrt{1 - v^2/c^2}}$$

Solving for  $v$  gives

$$1 - \frac{v^2}{c^2} = \frac{1}{9}$$

$$\frac{v^2}{c^2} = \frac{8}{9}$$

$$v = \frac{\sqrt{8}}{3} c = 2.83 \times 10^8 \text{ m/s}$$

(c) Determine the kinetic energy of the proton in electron volts.

**Solution**

$$KE = E - m_p c^2 = 3m_p c^2 - m_p c^2 = 2m_p c^2$$

Because  $m_p c^2 = 938 \text{ MeV}$ ,  $KE = 1880 \text{ MeV}$

## 26.10 GENERAL RELATIVITY

Optional Section

Up to this point, we have sidestepped a curious puzzle. Mass has two seemingly different properties: a *gravitational attraction* for other masses and an *inertial property* that resists acceleration. To designate these two attributes, we use the subscripts  $g$  and  $i$  and write

$$\begin{array}{ll} \text{Gravitational property} & F_g = m_g a \\ \text{Inertial property} & F_i = m_i a \end{array}$$

The value for the gravitational constant  $G$  was chosen to make the magnitudes of  $m_g$  and  $m_i$  numerically equal. Regardless of how  $G$  is chosen, however, the strict proportionality of  $m_g$  and  $m_i$  has been established experimentally to an extremely high degree: a few parts in  $10^{12}$ . Thus, it appears that gravitational mass and inertial mass may indeed be exactly proportional.

But why? They seem to involve two entirely different concepts: a force of mutual gravitational attraction between two masses and the resistance of a single mass to being accelerated. This question, which puzzled Newton and many other physicists over the years, was answered when Einstein published his theory of gravitation, known as *general relativity*, in 1916. Because it is a mathematically complex theory, we merely offer a hint of its elegance and insight.

In Einstein's view, the remarkable coincidence that  $m_g$  and  $m_i$  seemed to be exactly proportional was evidence for a very intimate and basic connection between the two concepts. He pointed out that no mechanical experiment (such as dropping a mass) could distinguish between the two situations illustrated in Figures 26.14a



and 26.14b. In each case, a mass released by the observer undergoes a downward acceleration of  $g$  relative to the floor.

Einstein carried this idea further and proposed that *no* experiment, mechanical or otherwise, could distinguish between the two cases. This extension to include all phenomena (not just mechanical ones) has interesting consequences. For example, suppose that a light pulse is sent horizontally across the box, as in Figure 26.14c. The trajectory of the light pulse bends downward as the box accelerates upward to meet it. Einstein proposed that a beam of light should also be bent downward by a gravitational field. (No such bending is predicted in Newton's theory of gravitation.)

The two postulates of Einstein's **general relativity** are as follows:

1. All the laws of nature have the same form for observers in any frame of reference, whether accelerated or not.
2. In the vicinity of any given point, a gravitational field is equivalent to an accelerated frame of reference in the absence of gravitational effects. (This is the *principle of equivalence*.)

The second postulate implies that gravitational mass and inertial mass are completely equivalent, not just proportional. What were thought to be two different types of mass are actually identical.

One interesting effect predicted by general relativity is that time scales are altered by gravity. A clock in the presence of gravity runs more slowly than one where gravity is negligible. As a consequence, the frequencies of radiation emitted by atoms in the presence of a strong gravitational field are shifted to lower frequencies when compared with the same emissions in a weak field. This gravitational shift has been detected in spectral lines emitted by atoms in massive stars. It has also been verified on the Earth by comparing the frequencies of gamma rays emitted from nuclei separated vertically by about 20 m.

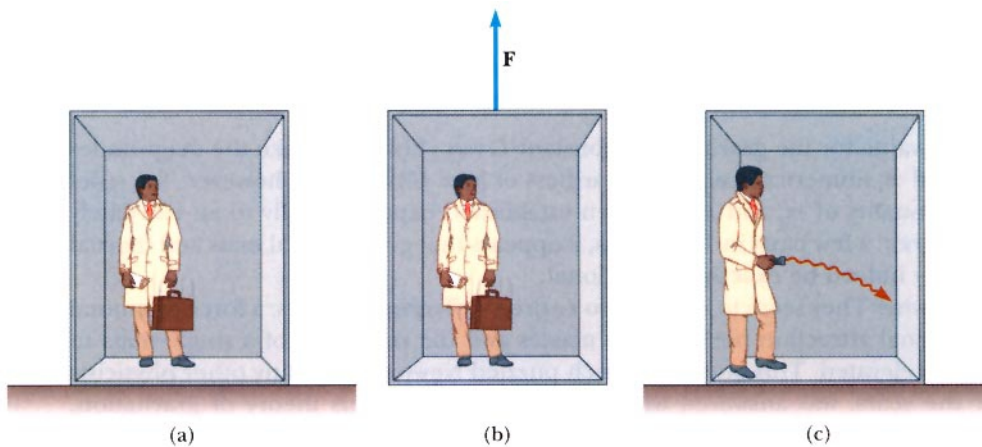

**Figure 26.14** (a) The observer is at rest in a uniform gravitational field  $\mathbf{g}$ . (b) The observer is in a region in which gravity is negligible, but the frame of reference is accelerated by an external force  $\mathbf{F}$  that produces an acceleration  $\mathbf{g}$ . According to Einstein, the frames of reference in parts (a) and (b) are equivalent in every way. No local experiment could distinguish any difference between the two frames. (c) If parts (a) and (b) are truly equivalent, as Einstein proposed, then a ray of light would bend in a gravitational field.

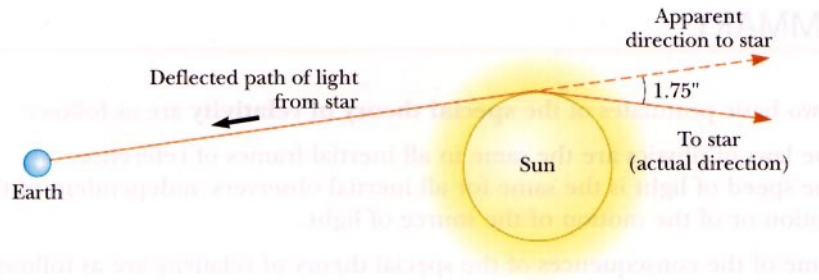

**Figure 26.15** Deflection of starlight passing near the Sun. Because of this effect, the Sun and other remote objects can act as a *gravitational lens*. In his general theory of relativity, Einstein calculated that starlight just grazing the Sun's surface should be deflected by an angle of  $1.75''$ .

The second postulate suggests that a gravitational field may be “transformed away” at any point if we choose an appropriate accelerated frame of reference—a freely falling one. Einstein developed an ingenious method of describing the acceleration necessary to make the gravitational field “disappear.” He specified a certain quantity, the *curvature of space-time*, that describes the gravitational effect at every point. In fact, the curvature of space-time completely replaces Newton's gravitational theory. According to Einstein, there is no such thing as a gravitational force. Rather, the presence of a mass causes a curvature of space-time in the vicinity of the mass, and this curvature dictates the space-time path that all freely moving objects must follow. As one physicist says, “Mass one tells space-time how to curve; curved space-time tells mass two how to move.” One important test of general relativity is the prediction that a light ray passing near the Sun should be deflected by some angle. This prediction was confirmed by astronomers as bending of starlight during a total solar eclipse shortly following World War I (Fig. 26.15).

If the concentration of mass becomes very great, as is believed to occur when a large star exhausts its nuclear fuel and collapses to a very small volume, a **black hole** may form. Here the curvature of space-time is so extreme that, within a certain distance from the center of the black hole, all matter and light become trapped.

### Thinking Physics 4

Atomic clocks are extremely accurate; in fact an error of 1 second in 3 million years is typical. This error can be described as about one part in  $10^{14}$ . On the other hand, the atomic clock in Boulder, Colorado, is often 15 ns faster than the one in Washington after only one day. This is an error of about one part in  $6 \times 10^{12}$ , which is about 17 times larger than the previously expressed error. If atomic clocks are so accurate, why does a clock in Boulder not remain in synchronism with one in Washington? (*Hint:* Denver, near Boulder, is known as the Mile High City.)

**Explanation** According to the general theory of relativity, the rate of passage of time depends on gravity—time runs more slowly in strong gravitational fields. Washington is at an elevation very close to sea level, whereas Boulder is about a mile higher in altitude. This will result in a weaker gravitational field at Boulder than at Washington. As a result, time runs more rapidly in Boulder than in Washington.

## SUMMARY

The two basic postulates of the **special theory of relativity** are as follows:

1. The laws of physics are the same in all inertial frames of reference.
2. The speed of light is the same for all inertial observers, independent of their motion or of the motion of the source of light.

Some of the consequences of the special theory of relativity are as follows:

1. Clocks in motion relative to an observer slow down. This is known as **time dilation**. The relationship between time intervals in the moving and at-rest systems is

$$\Delta t = \gamma \Delta t_p \quad [26.8]$$

where  $\Delta t$  is the time interval measured in the system in relative motion with respect to the clock,  $\gamma = 1/\sqrt{1 - v^2/c^2}$ , and  $\Delta t_p$  is the proper time interval measured in the system moving with the clock.

2. The length of an object in motion is *contracted* in the direction of motion. The equation for **length contraction** is

$$L = L_p \sqrt{1 - v^2/c^2} \quad [26.9]$$

where  $L$  is the length measured in the system in motion relative to the object, and  $L_p$  is the proper length measured in the system in which the object is at rest.

3. Events that are simultaneous for one observer are not simultaneous for another observer in motion relative to the first.

The relativistic expression for the **momentum** of a particle moving with a velocity  $v$  is

$$p \equiv \frac{mv}{\sqrt{1 - v^2/c^2}} = \gamma mv \quad [26.10]$$

The relativistic expression for the addition of velocities is

$$v_{ab} = \frac{v_{ad} + v_{db}}{1 + \frac{v_{ad}v_{db}}{c^2}} \quad [26.11]$$

where  $v_{ab}$  is the velocity of object  $a$  with respect to object  $b$ ,  $v_{ad}$  is the velocity of object  $a$  with respect to object  $d$ , and so forth.

The relativistic expression for the **kinetic energy** of an object is

$$KE = \gamma mc^2 - mc^2 \quad [26.12]$$

where  $mc^2$  is the **rest energy** of the object,  $E_R$ .

The **total energy** of a particle is

$$E = \frac{mc^2}{\sqrt{1 - v^2/c^2}} \quad [26.15]$$

This is Einstein's famous mass-energy equivalence equation.

The relativistic momentum is related to the total energy through the equation

$$E^2 = p^2 c^2 + (mc^2)^2 \quad [26.16]$$

## MULTIPLE-CHOICE QUESTIONS



- Which has the greatest momentum: a 1 MeV photon, or a proton or an electron with kinetic energy 1 MeV?  
(a) the photon (b) the proton (c) the electron  
(d) the electron and the proton (e) They are all the same.
- An electron with a kinetic energy  $2mc^2$  undergoes a head-on collision with another electron also with a kinetic energy of  $2mc^2$ . What is the kinetic energy of one of these electrons as viewed from the other electron just before the collision?  
(a)  $mc^2$  (b)  $2mc^2$  (c)  $4mc^2$  (d)  $8mc^2$  (e)  $16mc^2$
- A mass-spring system moving with simple harmonic motion has a period  $T$  when measured by a ground observer. If the same system is then placed in an inertial frame of reference that moves past the ground observer at a speed of  $0.50c$ , by what factor should  $T$  be multiplied to give the system's period as measured by the ground observer?  
(a) 0.50 (b) 0.87 (c) 1.0 (d) 1.2
- A spacecraft was originally 100 m long. However, it is now moving toward a tunnel with a speed of  $0.8c$ . The lady living near the tunnel can control doors that open and shut at each end of the tunnel and she has found that the tunnel is 65 m long. The doors are open as the spacecraft approaches but, the moment that the back of the spacecraft is in the tunnel, she closes both doors and then opens the doors very quickly. According to the captain on the spacecraft,  
(a) No door hit his spacecraft because the doors weren't closed simultaneously.  
(b) No door hit his spacecraft because he finds that length contraction makes his spacecraft only 60 m long.  
(c) No door hits the spacecraft because length contraction has made the tunnel 108.7 m long.  
(d) A door hits his spacecraft.
- The power output of the Sun is  $3.7 \times 10^{26}$  W. How much matter is converted into energy in the Sun every second?  
(a)  $4.1 \times 10^9$  kg/s (b)  $6.3 \times 10^9$  kg/s  
(c)  $7.4 \times 10^9$  kg/s (d)  $3.7 \times 10^9$  kg/s

## CONCEPTUAL QUESTIONS

- You are in a speedboat on a lake. You see ahead of you a wavefront, caused by the previous passage of another boat, moving away from you. You accelerate, catch up with, and pass the wavefront. Is this scenario possible if you are in a rocket and you detect a wavefront of light ahead of you?
- What two speed measurements will two observers in relative motion always agree on?
- Suppose astronauts were paid according to time spent traveling in space. After a long voyage traveling at a speed near that of light, astronauts return to Earth and open their pay envelopes. What will be their reaction?
- Consider the incorrect statement, "Matter can neither be created nor destroyed." How would you correct this statement in view of the special theory of relativity?
- You are packing for a trip to another star, to which you will be traveling at  $0.99c$ . Should you buy smaller sizes of your clothing, because you will be skinnier on the trip? Can you sleep in a smaller cabin than usual, because you will be shorter when you lie down?
- It is said that Einstein, in his teenage years, asked the question, "What would I see in a mirror if I carried it in my hands and ran at a speed near that of light?" How would you answer this question?
- You are observing a rocket moving away from you. You notice that it is measured to be shorter than when it was at rest on the ground next to you, and through the rocket window, you can see a clock. You observe that the passage of time on the clock is measured to be slower than that of the watch on your wrist. What if the rocket turns around and comes toward you? Will it appear to be longer and will the rocket-bound clock move faster?
- Two identically constructed clocks are synchronized. One is put in orbit around the Earth and the other remains on Earth. Which clock runs more slowly? When the moving clock returns to Earth, will the two clocks still be synchronized?
- A photon has a zero mass. If a photon is reflected from a surface, does it exert a force on the surface?
- Imagine an astronaut on a trip to Sirius, which is 8 light-years from the Earth. On arrival at Sirius, the astronaut finds that the trip lasted 6 years. If the trip was made at a constant speed of  $0.8c$ , how can the 8-lightyear distance be reconciled with the 6-year duration?
- Explain why it is necessary, when defining length, to specify that the positions of the ends of a rod are to be measured simultaneously.

12. The equation  $E = mc^2$  is often given in popular descriptions of Einstein's theory of relativity. Is this expression strictly correct? For example, does it accurately account for the kinetic energy of a moving mass?
13. Give a physical argument that shows that it is impossible to accelerate an object  $m$  to the speed of light, even with a continuous force acting on it.
14. Some distant star-like objects, called *quasars*, are receding from us at half the speed of light (or greater). What is the speed of the light we receive from these quasars?
15. List some ways our day-to-day lives would change if the speed of light were only 50 m/s.

## PROBLEMS

1, 2, 3 = straightforward, intermediate, challenging □ = full solution available in Study Guide/Student Solutions Manual  = Core Concepts Workbook  
 WEB = solution posted at <http://www.harcourcollege.com/physics/cptech>  = biomedical application  = Interactive Physics

### Review Problem

If 3.00 moles of a monatomic ideal gas are heated at constant volume so that the temperature of the gas rises 900°F, how much does the mass of the gas increase?

### Section 26.4 The Michelson–Morley Experiment

- Two airplanes fly paths I and II, specified in Figure 26.5a. Both planes have air speeds of 100 m/s and fly a distance  $L = 200$  km. The wind blows at 20.0 m/s in the direction shown in the figure. Find (a) the time of flight to each city, (b) the time to return, and (c) the difference in total flight times.
- In one version of the Michelson–Morley experiment, the lengths  $L$  in Figure 26.6 were 28 m. Take  $v$  to be  $3.0 \times 10^4$  m/s and find (a) the time difference caused by rotation of the interferometer and (b) the expected fringe shift, assuming that the light used has a wavelength of 550 nm.

### Section 26.6 Consequences of Special Relativity

- A deep-space probe moves away from Earth with a speed of  $0.80c$ . An antenna on the probe requires 3.0 s probe time to rotate through 1.0 rev. How much time is required for 1.0 rev according to an observer on Earth?
- An astronaut at rest on Earth has a heartbeat rate of 70 beats/min. When the astronaut is traveling in a spaceship at  $0.90c$ , what will this rate be as measured by (a) an observer also in the ship and (b) an observer at rest on the Earth?
- The average lifetime of a pi meson in its own frame of reference (i.e., the proper lifetime) is  $2.6 \times 10^{-8}$  s. If the meson moves with a speed of  $0.98c$ , what is (a) its mean lifetime as measured by an observer on Earth and (b) the average distance it travels before decaying as measured by an observer on Earth? (c) What distance would it travel if time dilation did not occur?
- If astronauts could travel at  $v = 0.950c$ , we on Earth would say it takes  $(4.20/0.950) = 4.42$  years to reach Alpha Centauri, 4.20 lightyears away. The astronauts dis-

agree. (a) How much time passes on the astronaut's clocks? (b) What is the distance to Alpha Centauri as measured by the astronauts?

- WEB  7. A muon formed high in the Earth's atmosphere travels at speed  $v = 0.99c$  for a distance of 4.6 km before it decays into an electron, a neutrino, and an antineutrino ( $\mu^- \rightarrow e^- + \nu + \bar{\nu}$ ). (a) How long does the muon live, as measured in its reference frame? (b) How far does the muon travel, as measured in its frame?
- A friend in a spaceship travels past you at a high speed. He tells you that his ship is 20 m long and that the identical ship you are sitting in is 19 m long. According to your observations, (a) how long is your ship, (b) how long is his ship, and (c) what is the speed of your friend's ship?
  - A box is cubical with sides of proper lengths  $L_1 = L_2 = L_3 = 2.0$  m, as shown in Figure P26.9, when viewed in its own rest frame. If this block moves parallel to one of its edges with a speed of  $0.80c$  past an observer, (a) what shape does it appear to have to this observer, and (b) what is the length of each side as measured by this observer?

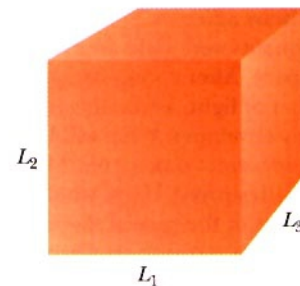

Figure P26.9

- With what speed must a clock move in order to run at a rate that is one half the rate of a clock at rest?

11. The proper length of one spaceship is three times that of another. The two spaceships are traveling in the same direction and, while both are passing overhead, an Earth observer measures the two spaceships to have the same length. If the slower spaceship is moving with a speed of  $0.35c$ , determine the speed of the faster spaceship.
12. A supertrain of proper length 100 m travels at a speed of  $0.95c$  as it passes through a tunnel having proper length 50 m. As seen by a trackside observer, is the train ever completely within the tunnel? If so, by how much?
13. An observer, moving at a speed of  $0.995c$  relative to a rod (Fig. P26.13), measures its length to be 2.00 m and sees its length to be oriented at  $30.0^\circ$  with respect to the direction of motion. (a) What is the proper length of the rod? (b) What is the orientation angle in a reference frame moving with the rod?

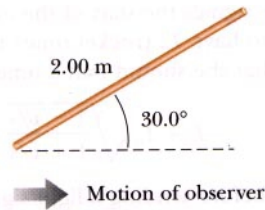

Figure P26.13 View of rod as seen by an observer moving to the right.

14. Observer A measures the length of two rods, one stationary, the other moving with a speed of  $0.955c$ . She finds that the rods have the same length,  $L_0$ . A second observer B travels along with the moving rod. What is the ratio of the length of A's rod to the length of B's rod according to observer B?

### Section 26.7 Relativistic Momentum

15. An electron has a speed  $v = 0.90c$ . At what speed will a proton have a momentum equal to that of the electron?
16. Calculate the momentum of an electron moving with a speed of (a)  $0.010c$ , (b)  $0.50c$ , (c)  $0.90c$ .
17. Show that the speed of an object having momentum  $p$  and mass  $m$  is given by

$$v = \frac{c}{\sqrt{1 + (mc/p)^2}}$$

18. An unstable particle at rest breaks up into two fragments of unequal mass. The mass of the lighter fragment is  $2.50 \times 10^{-28}$  kg, and that of the heavier fragment is  $1.67 \times 10^{-27}$  kg. If the lighter fragment has a speed of  $0.893c$  after the breakup, what is the speed of the heavier fragment?

- WEB 19. The nonrelativistic expression for the momentum of a particle,  $p = mv$ , can be used if  $v \ll c$ . For what speed does the use of this formula give an error in the momentum of (a) 1.00% and (b) 10.0%?

### Section 26.8 Relativistic Addition of Velocities

20. An electron moves to the right with a speed of  $0.90c$  relative to the laboratory frame. A proton moves to the left with a speed of  $0.70c$  relative to the electron. Find the speed of the proton relative to the laboratory frame.
21. Spaceship R is moving to the right at a speed of  $0.70c$  with respect to the Earth. A second spaceship, L, moves to the left at the same speed with respect to the Earth. What is the speed of L with respect to R?
22. A space vehicle is moving at a speed of  $0.75c$  with respect to an external observer. An atomic particle is projected at  $0.90c$  in the same direction as the spaceship's velocity with respect to an observer inside the vehicle. What is the speed of the projectile as seen by the external observer?
23. A rocket moves with a velocity of  $0.92c$  to the right with respect to a stationary observer A. An observer B moving relative to observer A finds that the rocket is moving with a velocity of  $0.95c$  to the left. What is the velocity of observer B relative to observer A? (*Hint:* Consider observer B's velocity in the frame of reference of the rocket.)
24. A pulsar is a stellar object that emits light in short bursts. Suppose a pulsar with a speed of  $0.950c$  approaches the Earth, and a rocket with a speed of  $0.995c$  heads toward the pulsar (both speeds measured in the Earth's frame of reference). If the pulsar emits 10.0 pulses per second in its own frame of reference, at what rate are the pulses emitted in the rocket's frame of reference?
25. Spaceship I, which contains students taking a physics exam, approaches Earth with a speed of  $0.60c$ , while spaceship II, which contains instructors proctoring the exam, moves away from Earth at  $0.28c$  as in Figure P26.25. If the instructors in spaceship II stop the exam after 50 min have passed on *their clock*, how long does the exam last as measured by (a) the students? (b) an observer on Earth?



Figure P26.25

## Section 26.9 Relativistic Energy

26. A proton moves with a speed of  $0.950c$ . Calculate its (a) rest energy, (b) total energy, and (c) kinetic energy.
27. A mass of  $0.50$  kg is converted completely into energy of other forms. (a) How much energy of other forms is produced and (b) how long will this much energy keep a  $100\text{-W}$  lightbulb burning?
28. The Sun radiates approximately  $4.0 \times 10^{26}$  J of energy into space each second. (a) How much mass is converted into energy of other forms each second? (b) If the mass of the Sun is  $2.0 \times 10^{30}$  kg, how long can the Sun survive if the energy transformation continues at the present rate?
29. What is the speed of a particle whose kinetic energy is equal to its own rest energy?
30. A proton in a high-energy accelerator is given a kinetic energy of  $50.0$  GeV. Determine (a) the momentum and (b) the speed of the proton.
31. In a color television tube, electrons are accelerated through a potential difference of  $20\,000$  volts. With what speed do the electrons strike the screen?
32. What speed must a particle attain before its kinetic energy is double the value predicted by the nonrelativistic expression  $KE = \frac{1}{2}mv^2$ ?
- WEB 33. An unstable particle with a mass equal to  $3.34 \times 10^{-27}$  kg is initially at rest. The particle decays into two fragments that fly off with velocities of  $0.987c$  and  $-0.868c$ . Find the masses of the fragments. (*Hint:* Conserve both mass-energy and momentum.)
34. If it takes  $3750$  MeV of work to accelerate a proton from rest to a speed of  $v$ , determine  $v$ .

## ADDITIONAL PROBLEMS

35. Determine the energy required to accelerate an electron from (a)  $0.500c$  to  $0.750c$  and (b)  $0.900c$  to  $0.990c$ .
36. How fast must a meter stick be moving if its length is observed to shrink to  $0.500$  m?
37. What is the speed of a proton that has been accelerated from rest through a difference of potential of (a)  $500$  V and (b)  $5.00 \times 10^8$  V?
38. An electron has a total energy equal to five times its rest energy. (a) What is its momentum? (b) Repeat for a proton.
39. What is the momentum (in units of  $\text{MeV}/c$ ) of an electron with a kinetic energy of  $1.00$  MeV?
40. An alarm clock is set to sound in  $10$  h. At  $t = 0$  the clock is placed in a spaceship moving with a speed of  $0.75c$  (relative to the Earth). What distance, as determined by an Earth observer, does the spaceship travel before the alarm clock sounds?
41. At what speed must an electron move for its energy to equal a proton's rest energy?
42. A radioactive nucleus moves with a speed of  $v$  relative to a laboratory observer. The nucleus emits an electron in

the positive  $x$  direction with a speed of  $0.70c$  relative to the decaying nucleus and a speed of  $0.85c$  in the  $+x$  direction relative to the laboratory observer. What is the value of  $v$ ?

43. A certain quasar recedes from the Earth at  $v = 0.870c$ . A jet of material ejected from the quasar back toward the Earth moves at  $0.550c$  relative to the quasar. Find the speed of the ejected material relative to the Earth.
44. A spaceship of proper length  $300$  m takes  $0.75 \mu\text{s}$  to pass an Earth observer. Determine the speed of this spaceship as measured by the Earth observer.
45. Find the kinetic energy of a  $78.0\text{-kg}$  spacecraft launched out of the Solar System with speed  $106$  km/s by using (a) the classical equation  $KE = \frac{1}{2}mv^2$  and (b) the relativistic equation.
46. A physics professor on Earth gives an exam to her students who are on a rocketship traveling at speed of  $v$  with respect to Earth. The moment the ship passes the professor, she signals the start of the exam. If she wishes her students to have  $T_0$  (rocket time) to complete the exam, show that she should wait a time of

$$T = T_0 \sqrt{\frac{1 - v/c}{1 + v/c}}$$

(Earth time) before sending a light signal telling them to stop. (*Hint:* Remember that it takes some time for the second light signal to travel from the professor to the students.)

47. Imagine that the entire Sun collapses to a sphere of radius  $R_g$  such that the work required to remove a small mass  $m$  from the surface would be equal to its rest energy  $mc^2$ . This radius is called the *gravitational radius* for the Sun. Find  $R_g$ . (It is believed that the ultimate fate of many stars is to collapse to their gravitational radii or smaller.)
48. A rod of length  $L_0$  moves with a speed of  $v$  along the horizontal direction. The rod makes an angle of  $\theta_0$  with respect to the axis of a coordinate system moving with the rod. (a) Show that the length of the rod as measured by a stationary observer is given by

$$L = L_0 \left[ 1 - \left( \frac{v^2}{c^2} \right) \cos^2 \theta_0 \right]^{1/2}$$

(b) Show that the angle the rod makes with the axis as seen by the stationary observer is given by the expression  $\tan \theta = \gamma \tan \theta_0$ . These results show that the rod is both contracted and rotated. (Take the lower end of the rod to be at the origin of the moving coordinate system.)

49. Ted and Mary are playing a game of catch in frame  $S'$ , which is moving with a speed of  $0.60c$ ; Jim in frame  $S$  is watching (Fig. P26.49). Ted throws the ball to Mary with a speed of  $0.80c$  (according to Ted) and their separation (measured in  $S'$ ) is  $1.80 \times 10^{12}$  m. (a) According to

Mary, how fast is the ball moving? (b) According to Mary, how long will it take the ball to reach her? (c) According to Jim, how far apart are Ted and Mary, and how fast is the ball moving?

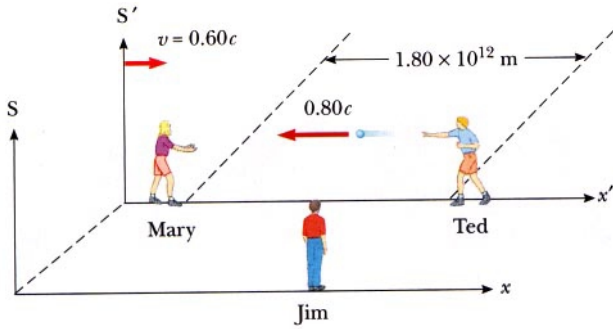

Figure P26.49

in  $S'$  at the origin in  $S'$  (as measured by observers in  $S'$ ). At the instant their origins coincide, Matt throws a ball toward Jennifer at constant speed  $0.80c$  as measured by Matt (Fig. P26.51). (a) What is the speed of the ball as measured by Jennifer? How long before Jennifer catches the ball, as measured by (b) Jennifer, (c) the ball, and (d) Matt?

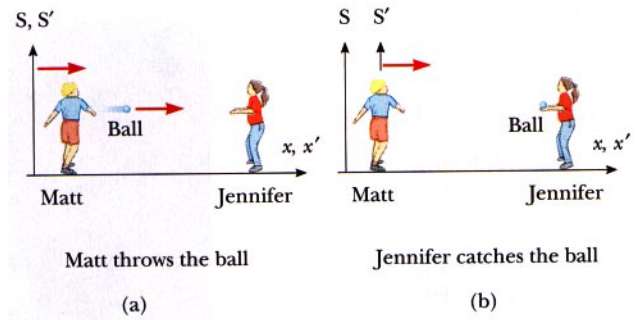

Figure P26.51

- WEB 50. (a) Show that a potential difference of  $1.02 \times 10^6$  V would be sufficient to give an electron a speed equal to twice the speed of light if Newtonian mechanics remained valid at high speeds. (b) What speed would an electron actually acquire in falling through a potential difference of  $1.02 \times 10^6$  V?
51. Consider two inertial reference frames,  $S$  and  $S'$ , where  $S'$  is moving to the right with constant speed  $0.60c$  as measured by observers in  $S$ . Jennifer is located  $1.80 \times 10^{11}$  m to the right of the origin of  $S$  and is fixed in  $S$  (as measured by observers in  $S$ ), and Matt is fixed

52. The muon is an unstable particle that spontaneously decays into an electron and two neutrinos. If the number of muons at  $t = 0$  is  $N_0$ , the number at time  $t$  is given by  $N = N_0 e^{-t/\tau}$  where  $\tau$  is the mean lifetime, equal to  $2.2 \mu\text{s}$ . Suppose that the muons move at a speed of  $0.95c$  and that there are  $5.0 \times 10^4$  muons at  $t = 0$ . (a) What is the observed lifetime of the muons? (b) How many muons remain after traveling a distance of 3.0 km?

